



Service Manual

DIGITAL LIGHT PROCESSING™ PROJECTION TV
VK26 CHASSIS



MODELS
WD-52327
WD-62327

CAUTION:

Before servicing this chassis, it is important that the service person read the "SAFETY PRECAUTIONS" and "PRODUCT SAFETY NOTICE" contained in this manual.

SPECIFICATIONS

- | | | | |
|--------------------------------|--|-----------------------|--|
| • Power Input | : AC 120V, 60Hz | • Input Level | : VIDEO IN JACK (RCA Type)
1.0Vp-p 75Ω unbalanced |
| • Power Usage | : 200W | | : AUDIO IN JACK (RCA Type)
-4.7dBm 43kΩ unbalanced |
| • Light Engine | : DLP (1280 x 720p pixels) | | : S-VIDEO IN JACK
(Y/C separate type)
Y:1.0 Vp-p C:0.286Vp-p(BURST)
75Ω unbalanced |
| • Light Source | : 120W VIP | | : COMP / Y, Cr, Cb (RCA Type)
Y: 1.0 Vp-p Cr, Cb: 700mVp-p |
| • Frequency Range | : VHF 54 ~ 470MHz
UHF 470 ~ 806MHz | | : DTV / Y(G), Pr(R), Pb(B), H, V
Y: 1.0Vp-p with sync 75Ω (BNC)
Pr, Pb: 700mV 75Ω
H, V: 3.0Vp-p 75Ω |
| • Antenna Input | : VHF/UHF 75Ω unbalanced
2 - NTSC | | |
| • Cabinet Dimensions | WD-52327
: 37.2"(H) x 49.6"(w) x 17.4"(D)
WD-62327
: 43.7"(H) x 58.3"(W) x 19.9"(D) | • Output Level | : VIDEO OUT JACK (RCA Type)
1.0Vp-p 75Ω unbalanced |
| • Weight | [WD-52327] 110 lbs
[WD-62327] 139 lbs | | : AUDIO OUT JACK (RCA Type)
-4.7dBm 4.7kΩ unbalanced |
| • Speakers (8 Ohms 10W) | : 2-5 inch Coaxial | • Digital | : MonitorLink™/DVI |

• Design specifications are subject to change without notice.

MITSUBISHI DIGITAL ELECTRONICS AMERICA, INC.

9351 Jeronimo Road, Irvine, CA 92618-1904

Copyright © 2004 Mitsubishi Digital Electronics America, Inc.

All Rights Reserved

CONTENTS

INTRODUCTION	5
PRODUCT SAFETY NOTICE	5
SAFETY PRECAUTIONS	6
DISASSEMBLY	
WD-52327 & WD-62327	
Front Cabinet Components	7
Rear Cabinet Components	8
CHASSIS REMOVAL	
Chassis removal procedure	9
Shield Removal	10
Chassis PWB locations	11
Accessing the Lamp Ballast	12
OPTICAL ENGINE REPLACEMENT	
Optical Engine Mounting	13
Removing the Optical Engine	14
Removing DMD Heat Sensor	15
Removing Bottom Plate & Black Support Bracket	15
Installing the Optical Engine	16
SERVICING THE LENTICULAR SCREEN AND FRESNEL LENS	
Removal of the Lenticular Screen and Fresnel Lens	17
Installation of the Lenticular Screen and Fresnel Lens	19
ELECTRICAL ADJUSTMENTS	
Equipment	20
Initial Setup (Option Menu)	21
Main Menu Defaults	21
A/V Memory Defaults	22
LED Indications	22
LED Diagnostic Check	23
Circuit Adjustment Mode	23
Adjustment Items List	25
Activating Internal Test Patterns	26
Adjustment Procedures	27
Main & Sub Y level adjustments	27
Main & Sub Color level adjustments	27
White Balance Adjustments	28
Horizontal & Vertical Position adjustments	28
Mechanical Adjustments	29
Required Front Disassembly	29
Required Rear Disassembly	29
Picture Rotation Adjustment	30
Horizontal & Vertical Keystone Distortion adjustments	31
QUICK REFERENCE PART LIST	32
Service Parts List	33
Screen Parts List	41
CIRCUITRY BLOCK DIAGRAMS	
Standby power Supplies	42
Switched Supplies	42

Switched DC to DC Supplies	43
Video/Color Signal Path	44
Sound Signal Path	45
Sync Signal Path	46
Control Circuit (Commands, Serial Data & Reset)	47
Control Circuit (Status Inputs, OSD Insert & CCD Insert)	48
PWB-FORMAT Block Diagram	49

SCHEMATIC DIAGRAMS

BLOCK (PWB INTERCONNECTIONS)	S1
------------------------------------	----

1

INTRODUCTION

This service manual provides service instructions for PTV models WD-52327 and WD-62327, using the VK26 chassis.

This service manual includes:

1. Assembly and disassembly instructions for the front and rear cabinet components.
2. Servicing of the Lenticular Screen and Fresnel Lens.
3. Servicing to PWB level. The Optical Engine and Lamp Ballast are considered replaceable components.
4. Electrical and Mechanical adjustments.
5. Chip parts replacement procedures.
6. Simplified signal path block diagrams.

The parts list section of this service manual includes:

1. Cabinet and screen parts.
2. Electrical parts.

Block diagrams of the above listed models are included in this service manual for better understanding of the circuitry.

PRODUCT SAFETY NOTICE

Many electrical and mechanical parts in television receivers have special safety related characteristics. These characteristics are often not evident from visual inspection nor can the protection afforded by them necessarily be obtained by using replacement components rated for higher voltage, wattage, etc.

Replacement parts which have special safety characteristics are identified in this service manual.

Electrical components having such features are identified by shading on the schematic diagram and by bold type in the parts list of this service manual. **Therefore, the replacement for any safety part should be identical in value and characteristics.**

SAFETY PRECAUTIONS

NOTICE: Observe all cautions and safety related notes located inside the receiver cabinet and on the receiver chassis.

WARNING:

1. Operation of this receiver outside the cabinet or with the cover removed presents a shock hazard from the receiver's power supplies. Work on the receiver should not be attempted by anyone who is not thoroughly familiar with the precautions necessary when working on high voltage equipment.
2. When service is required, observe the original lead dress. Extra precaution should be taken to assure correct lead dress in the high voltage area. Where a short-circuit has occurred, replace those components that indicate evidence of overheating.

WARNING ... RISK OF EYE INJURY
Do not look into the light source, Light Engine lens or mirror when operating the TV

Leakage current check

Before returning the receiver to the customer, it is recommended that leakage current be measured according to the following methods.

1. Cold Check

With the alternating current (AC) plug removed from the AC source, place a jumper across the two AC plug prongs. Connect one lead of an ohm meter to the AC plug and touch the other lead to each exposed metal part (i.e. antennas, handle bracket, metal cabinet, screw heads, metal overlay, control shafts, etc.), particularly any exposed metal part that has a return path to the chassis. The resistance of the exposed metal parts having a return path to the chassis **should be a minimum of 1Mega Ohm**. Any resistance below this value indicates an abnormal condition and requires corrective action.

2. Hot Check ...Use the circuit shown below to perform the hot check test.

1. Keep switch S1 open and connect the receiver to the measuring circuit. Immediately after connection, and with the switching devices of the receiver in their operating positions, measure the leakage current for both positions of switch S2.
2. Close switch S1, energizing the receiver. Immediately after closing switch S1, and with the switching devices of the receiver in their operating positions, measure the leakage current for both positions of switch S2. Repeat the current measurements of items 1 and 2 after the receiver has reached thermal stabilization. **The leakage current must not exceed 0.5 milliampere (mA).**

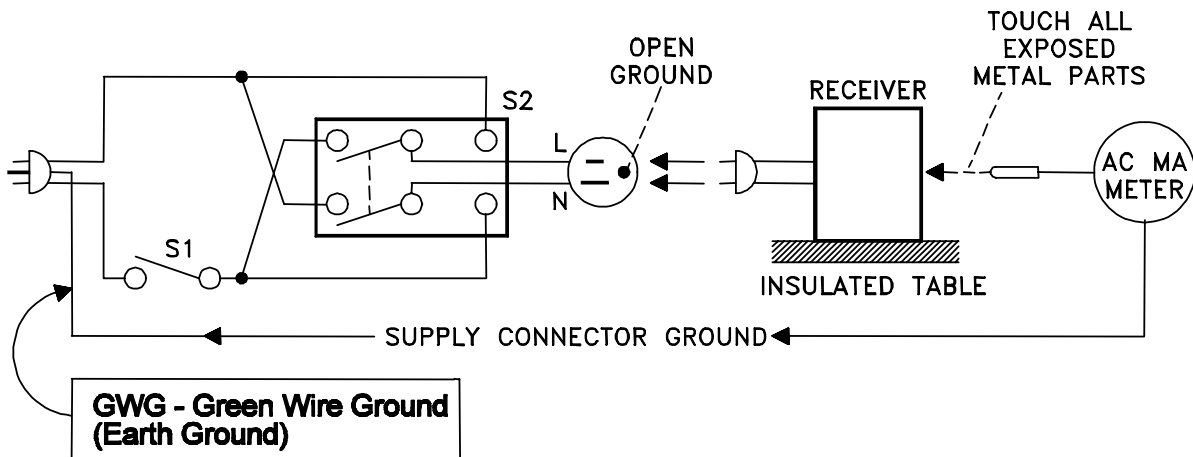

CABINET DISASSEMBLY (FRONT VIEW) WD-52327 / WD-62327

*Refer to the Parts List for Part Numbers

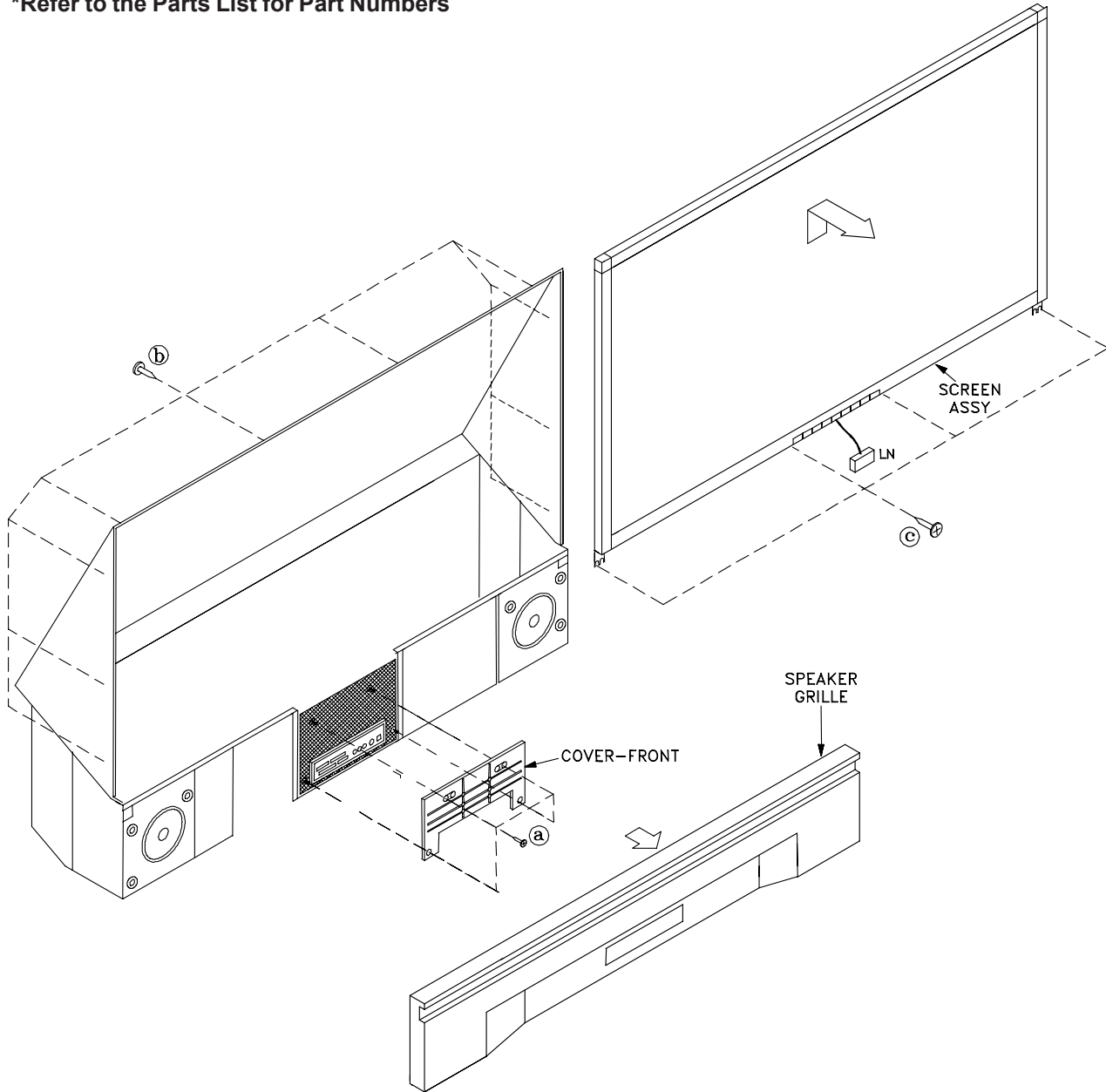

Front Cabinet Disassembly

1. Remove the SPEAKER-GRILLE by pulling forward.
2. Remove screws (a) to remove the COVER-FRONT.
3. Remove screws (b) on the rear of the upper back cover (4 across the top and 3 on each side).
4. Remove the 4 screws (c) holding the bottom of the Screen Assembly.
5. Unplug connector LN from the Control Panel.
6. Lift the Screen Assembly up slightly then pull towards the front to remove the assembly.

REAR DISASSEMBLY

FILTER-COVER Removal

Remove 2 screws (d) to remove the Filter Cover.

COVER-BACK Removal

- 1) Remove 9 screws (a)
- 2) Remove 6 screws (b)
- 3) Remove 2 screws (c)
- 4) Pull the COVER-BACK from the cabinet.

NOTE: To operate the TV with the COVER-BACK removed, the FILTER-COVER must be reinstalled.

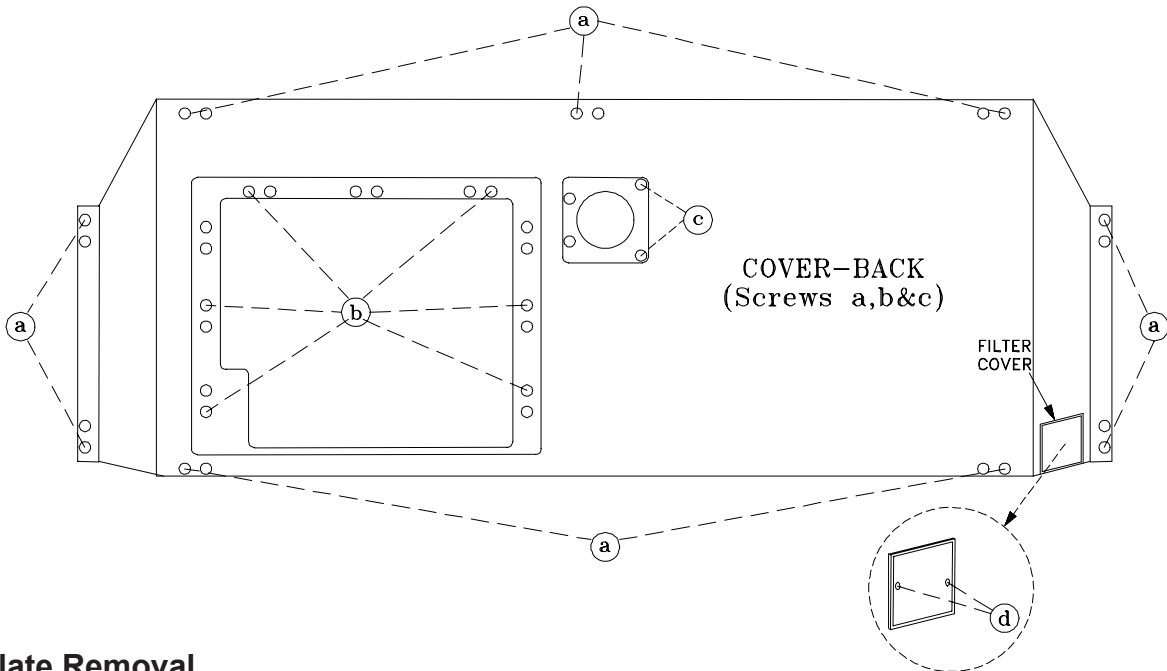

Rear Plate Removal

- 1) Remove 6 screws (a)
- 2) Remove 6 screws (b)
- 3) Pull the COVER-BACK from the cabinet.
- 4) Lay the Rear Plate down behind the TV.

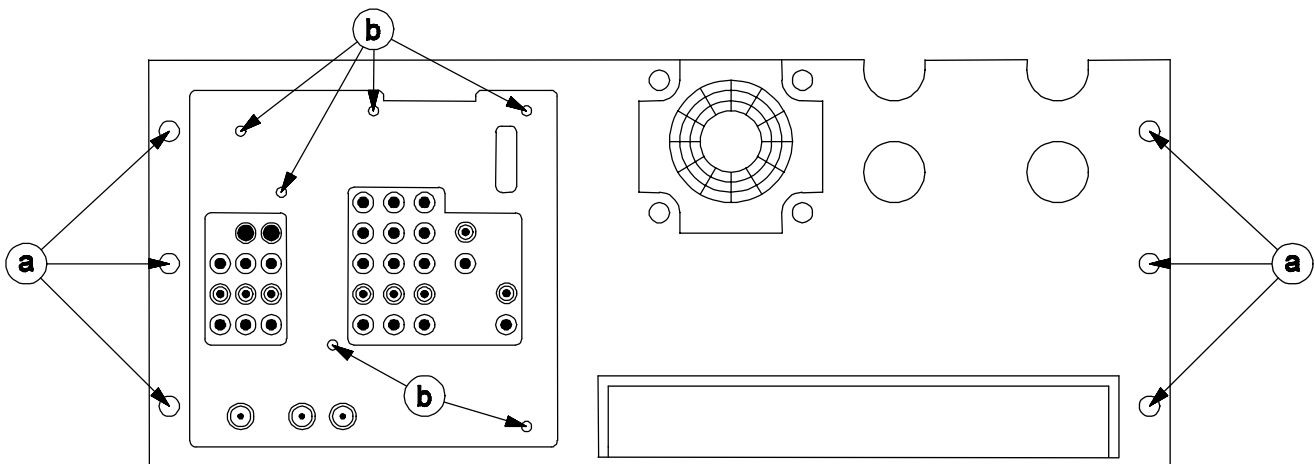

CHASSIS REMOVAL

Chassis Removal Procedure

- 1) Disconnect all relay connectors shown below (JE, CC, JJ, PP, LL & EE)
- 2) Disconnect the J9 and DVI connectors at the Optical Engine.
- 2) Remove three screws (a) securing the chassis.
- 3) Carefully slide the chassis from the cabinet.

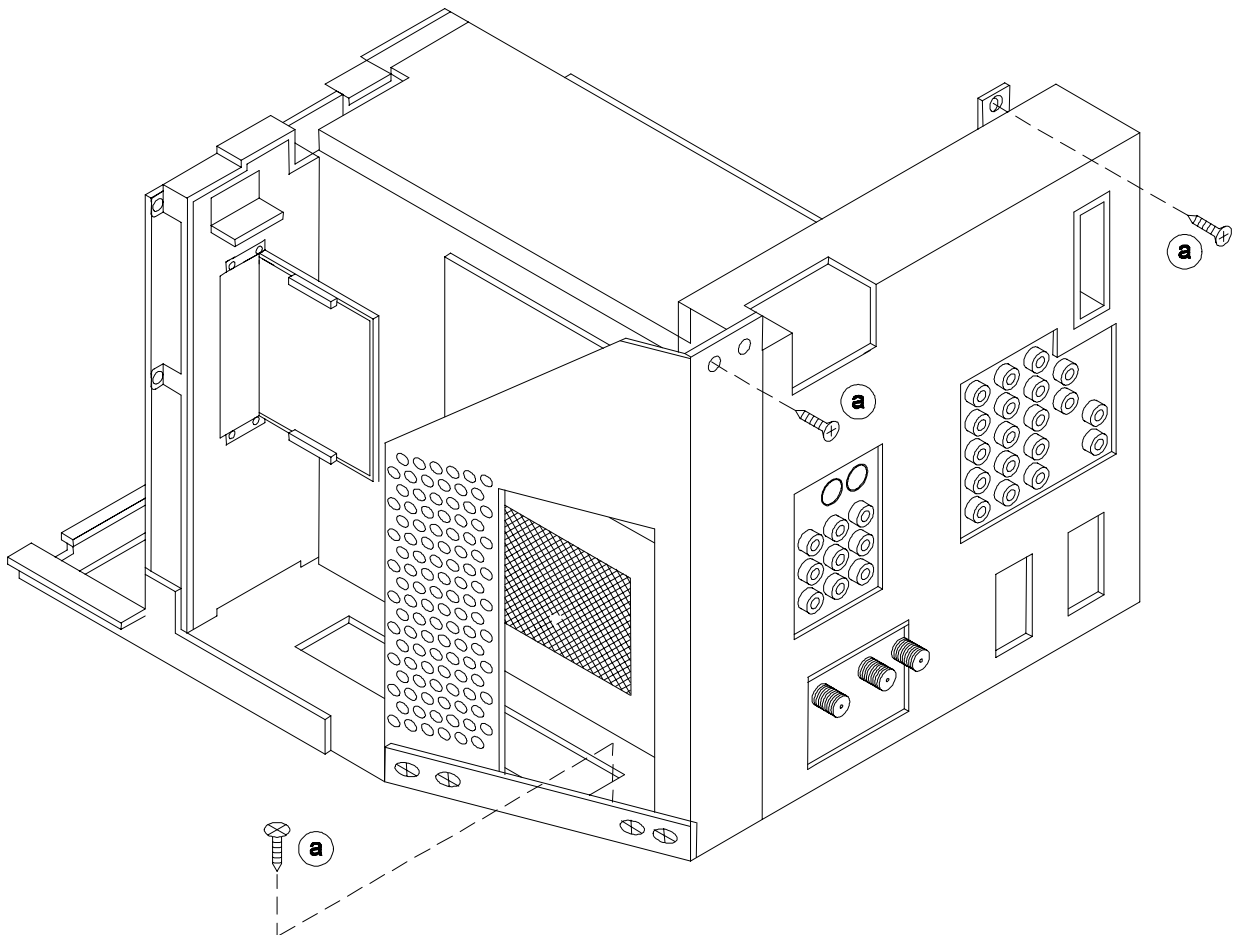
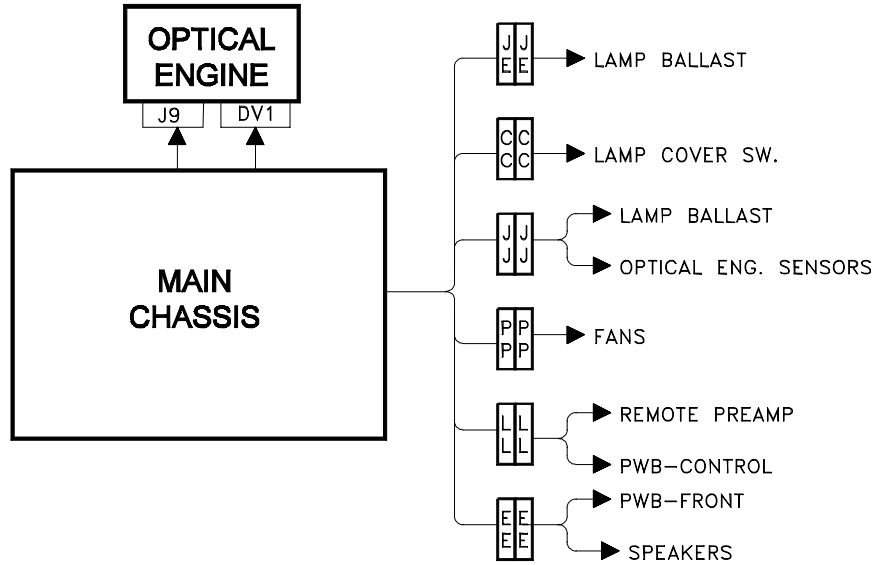

Shield Removal

- 1) To remove SHIELD-COVER, remove 11 screws (a).
- 2) To remove PWB-TERMINAL COVER, remove 9 screws (b).

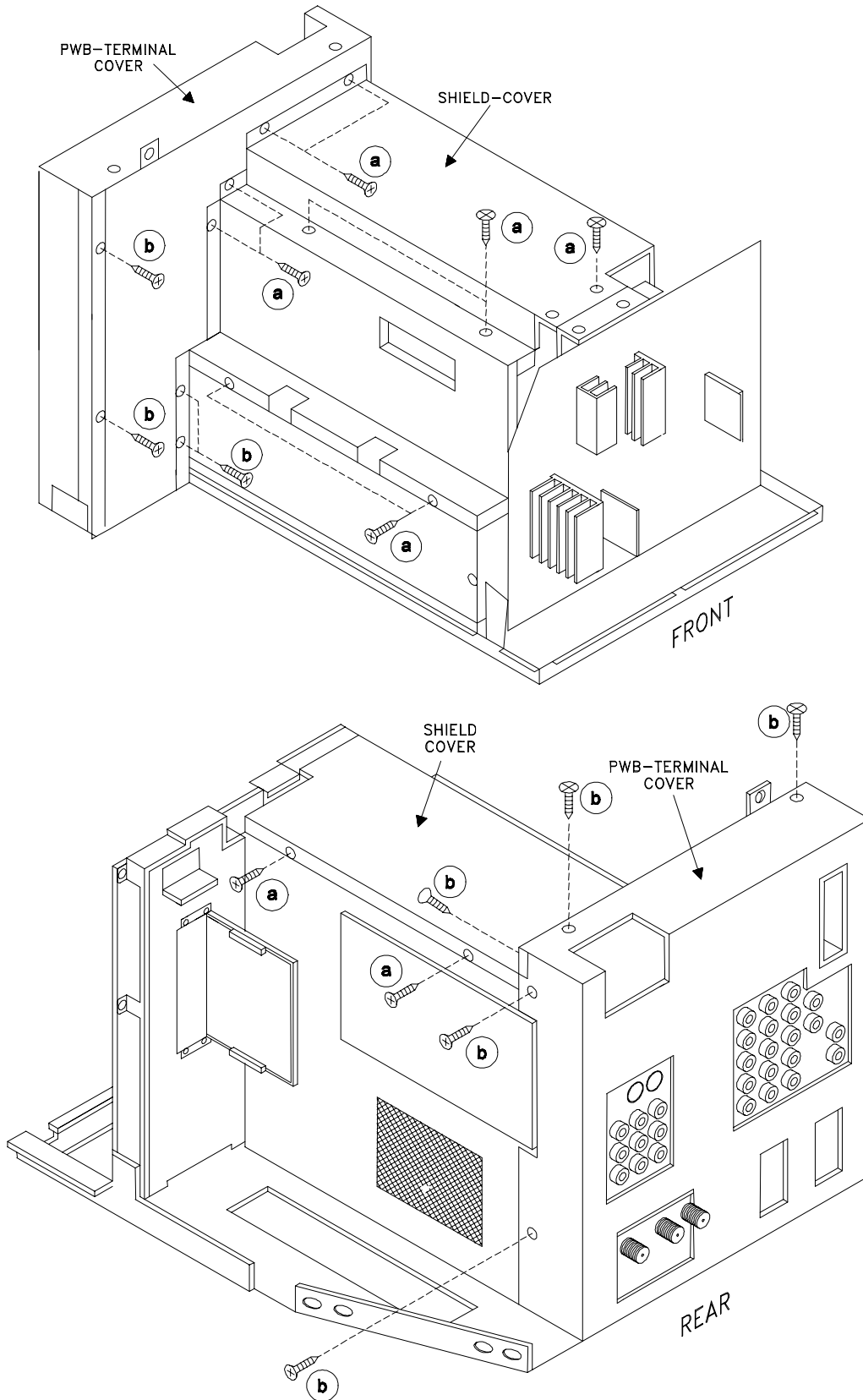

VK26 Chassis PWB Locations (Shield-Cover removed)

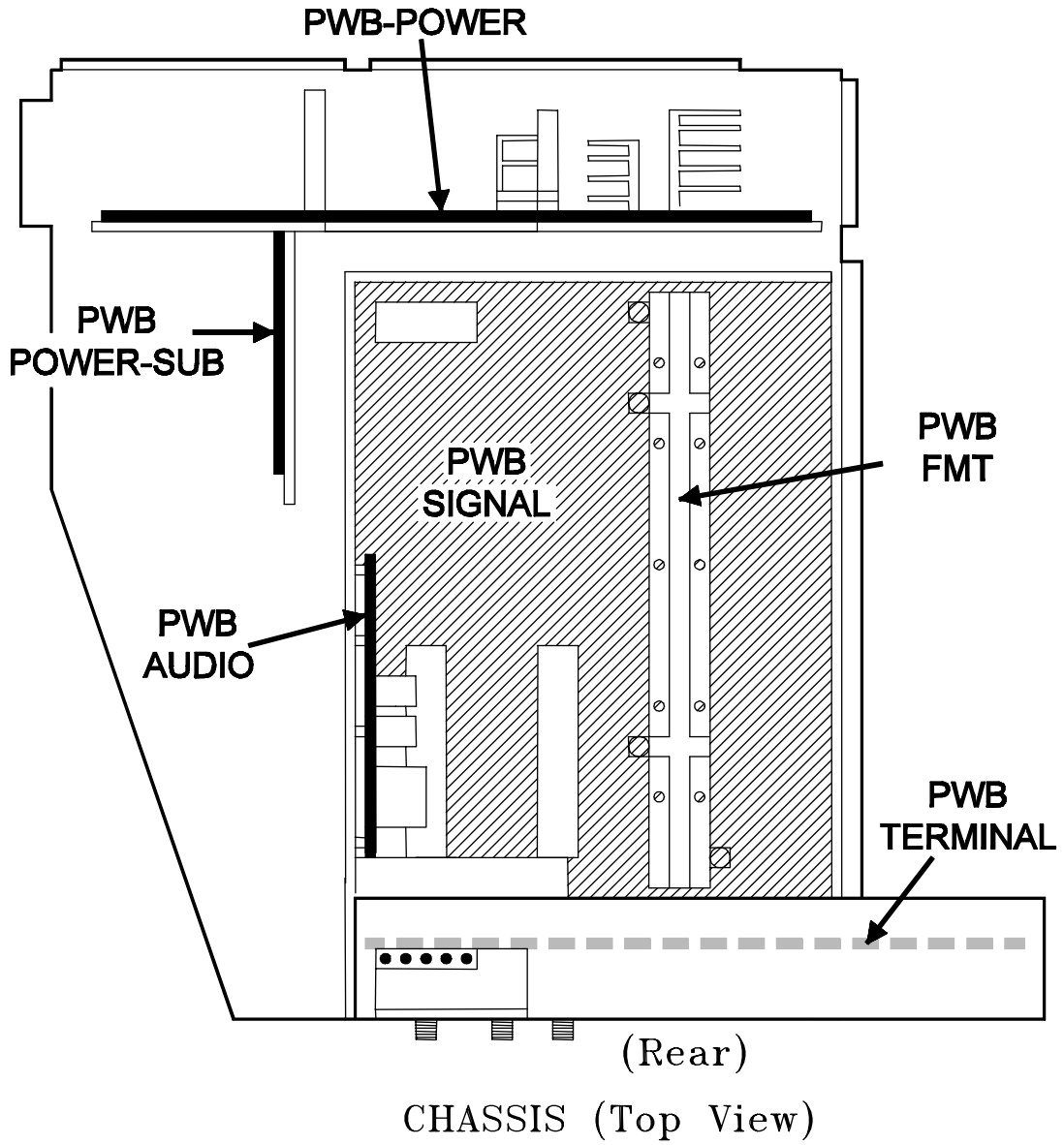

Accessing The Lamp Ballast

Removing the Right Support (Rear View)

- 1) Remove the Air Filter.
- 2) Remove the 3 screws (a).
- 3) Lift the upper cabinet slightly to remove the support bracket.

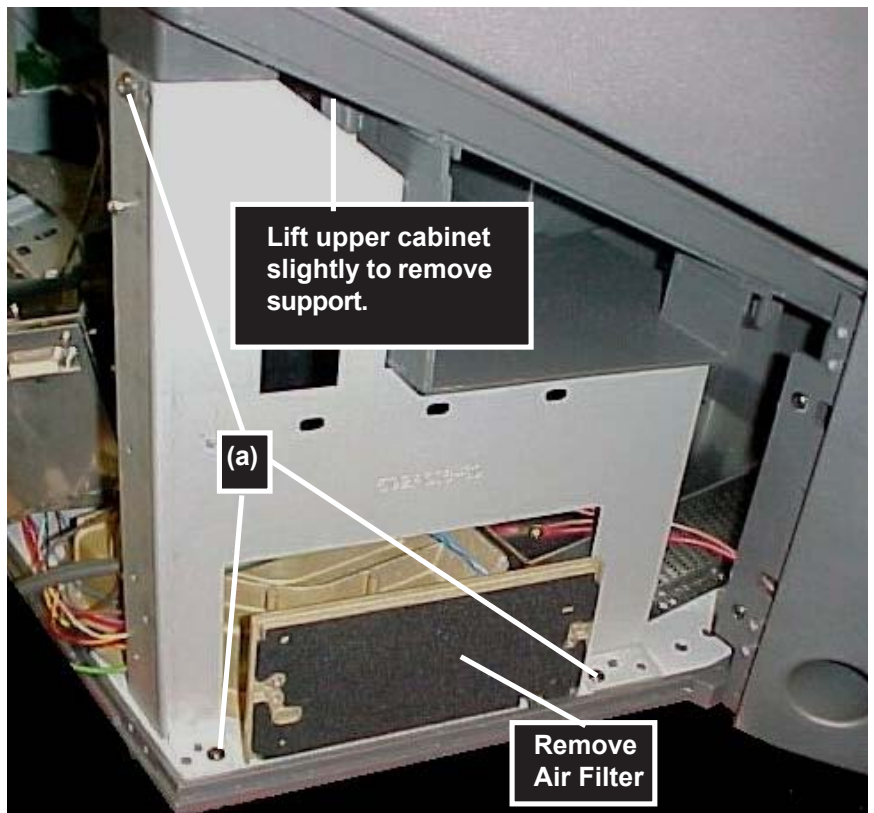

Removing the Lamp Ballast Shield (4 screws)

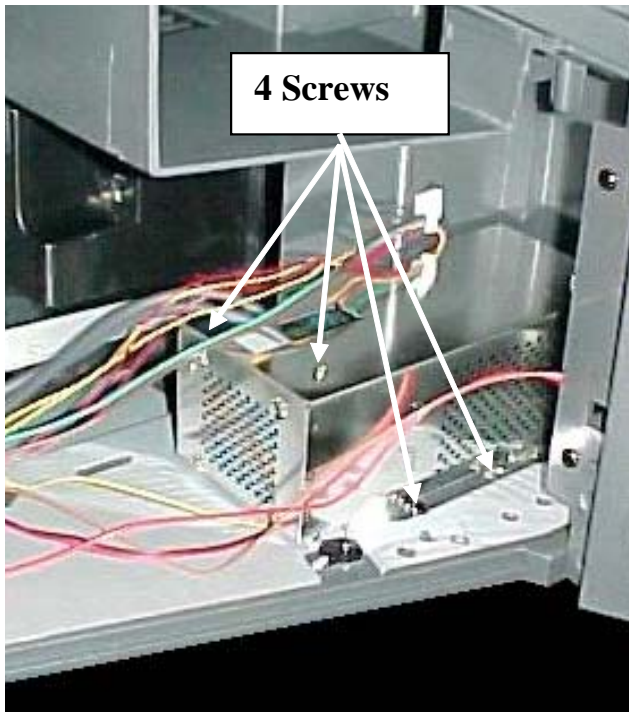

Unplug CJ3 & CN2 Connectors

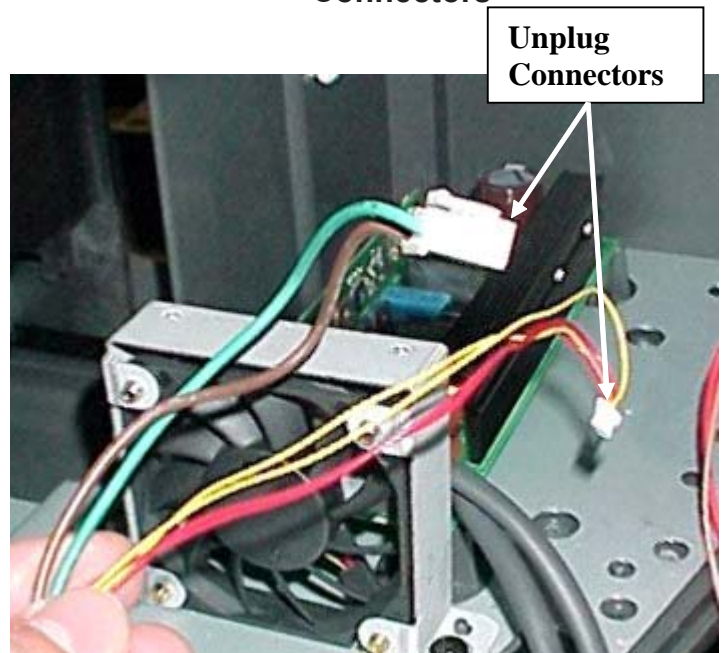

OPTICAL ENGINE REPLACEMENT

Optical Engine is mounted on the Adjuster assembly as shown below.

- 1) The Optical Engine is secured to the bottom plate with 4 screws (b).
- 2) The Black Bracket is secured to the bottom plate and the Lamp Cartridge Housing with 4 screws (c).
- 3) Tab (1) on the bottom plate slides into slot (1) on the Adjuster assembly.
- 4) 4 screws (a) secure the bottom plate and Optical Engine to the Adjuster assembly.
- 5) The Optical Engine, the bottom plate, black bracket and the Optical Engine are removed as a unit.

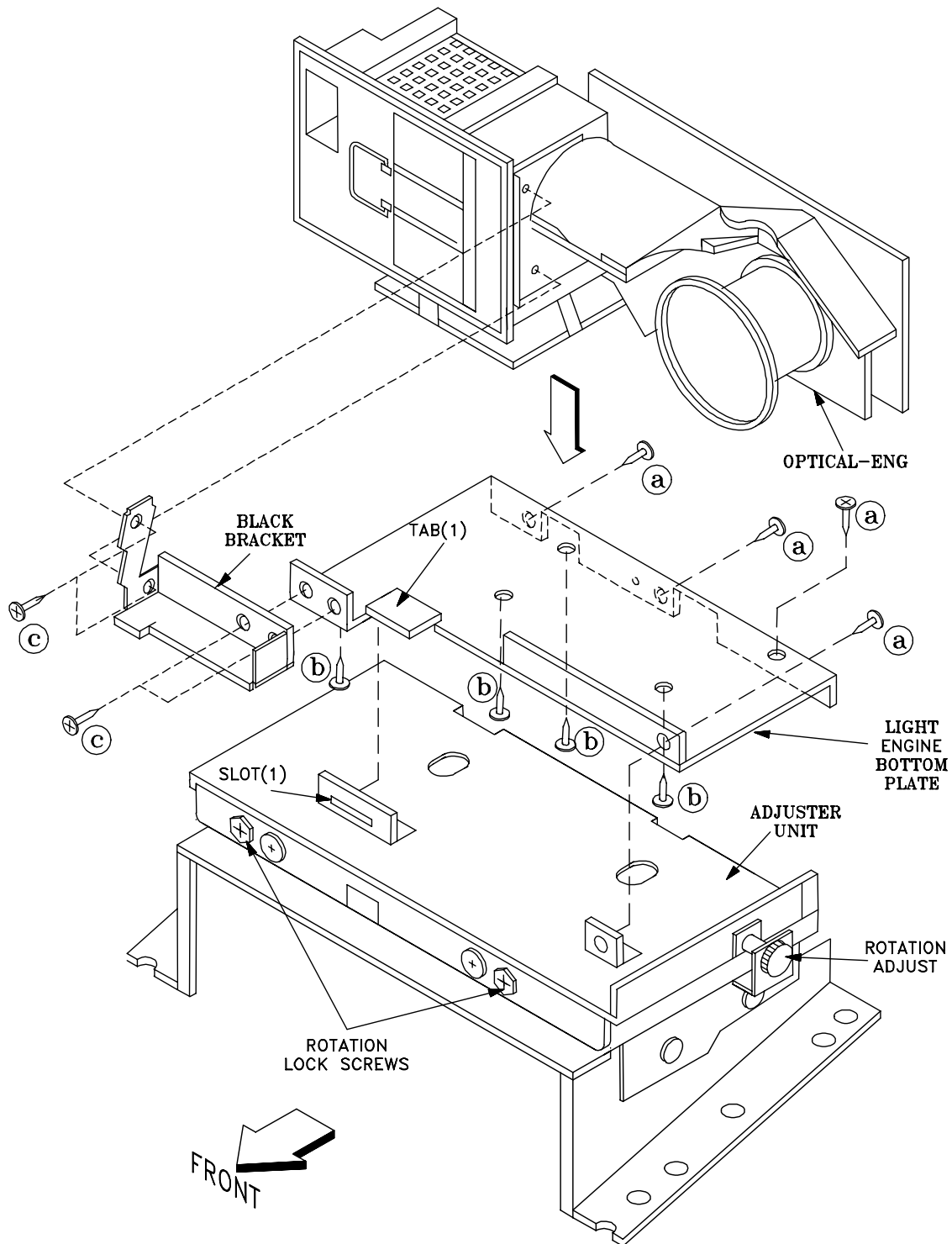

Removing the Optical Engine

- 1) Remove the Cabinet BACK-BOARD and REAR-PLATE (refer to disassembly instructions).
- 2) Disconnect all connectors connected to the Engine and the PWB-FORMAT.
- 3) From the rear of the TV, remove the 4 screws (c), to remove the COVER-DUCT and DMD Fan cover.
- 4) From the rear of the TV, remove the 4 screws (a), shown below, securing the bottom plate to the Adjuster assembly.
- 5) Slide the Optical Engine, PWB-DMD and bottom plate towards the rear to remove the unit from the TV.

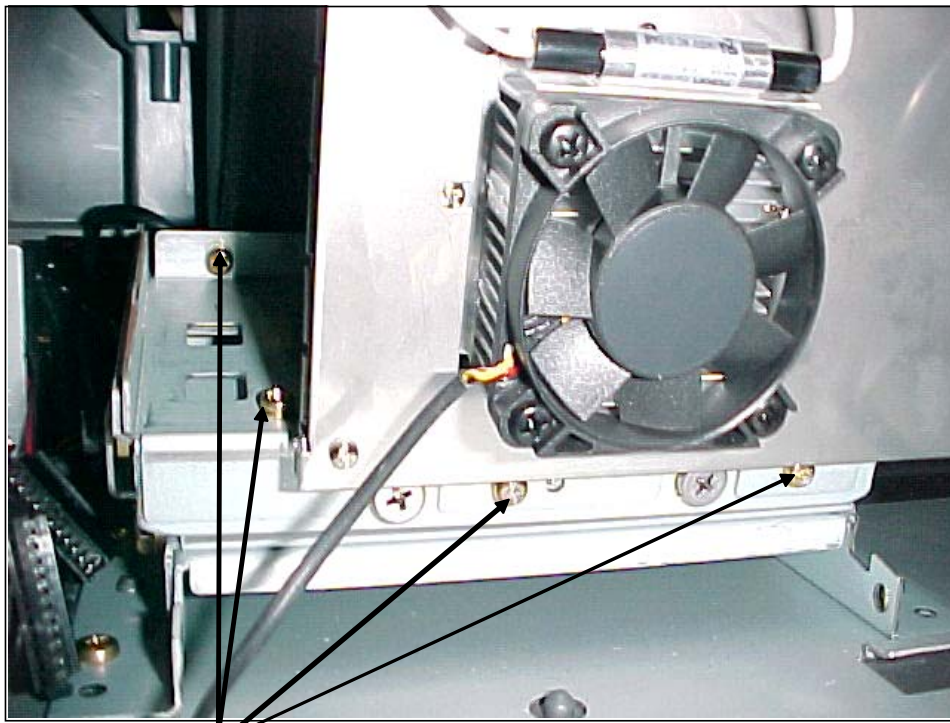
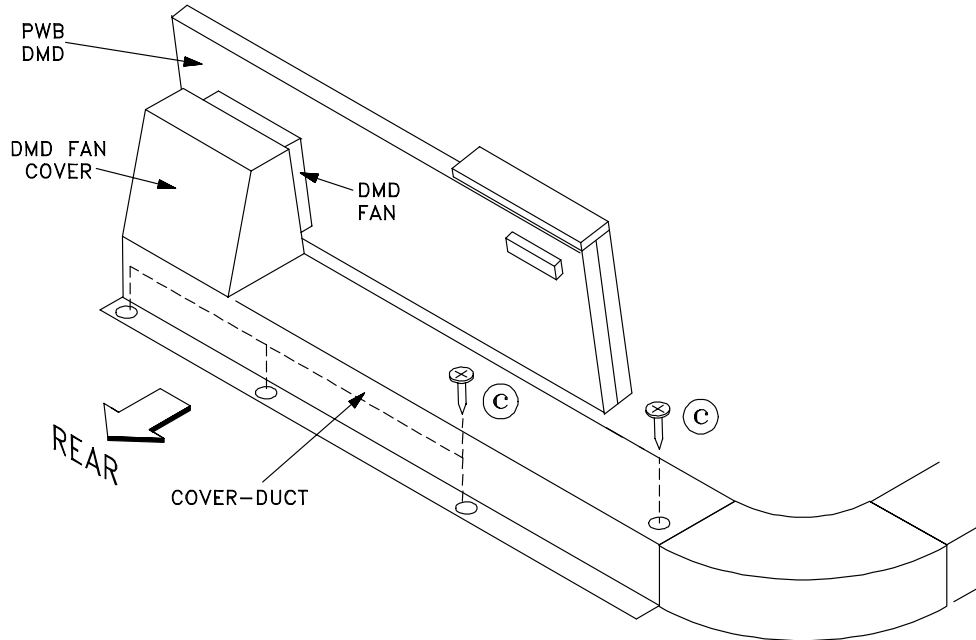

(a)

Optical Engine (Rear View / Airt duct & DMD Fan Cover Removed)

Remove the following parts from the Optical Engine

- DMD Thermal Sensor
- The Optical Engine bottom plate and black bracket

DMD Thermal Sensor Removal (*Figure 1*)

- 1) Remove screw (a) on the top of the DMD Fan.
- 2) Set the Thermal Sensor aside to install on the replacement Optical Engine.

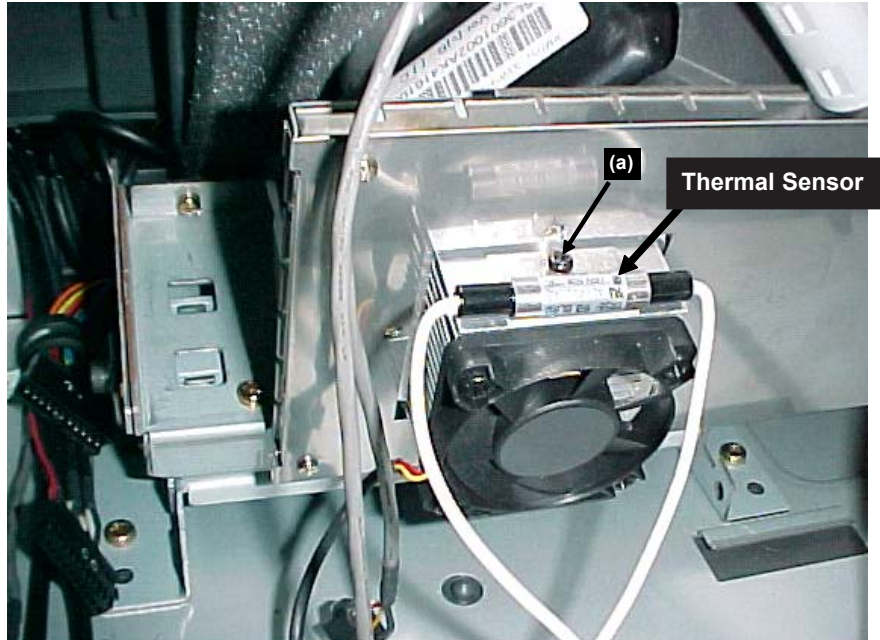

Figure 1: DMD Thermal Sensor

Bottom Plate & Black Bracket Removal

- 1) Remove the 4 screws (B) from the Bottom Plate (*Figure 2*)
- 2) Remove the two screws (c), holding the Black Bracket to the Lamp Cartridge Housing. (*Figure 3*)

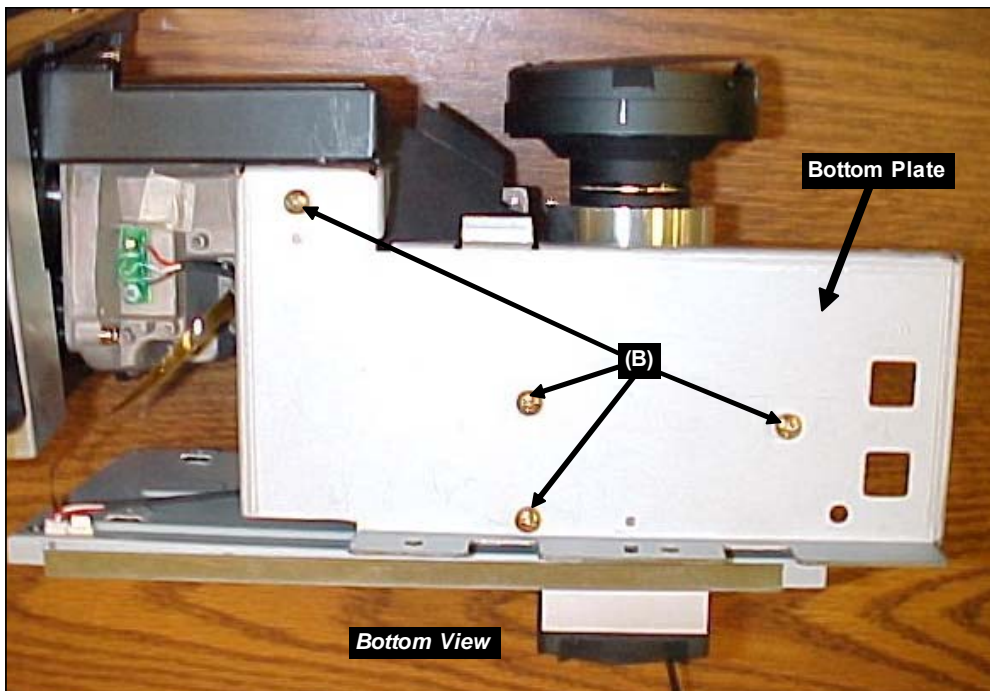

Figure 2: Bottom Plate

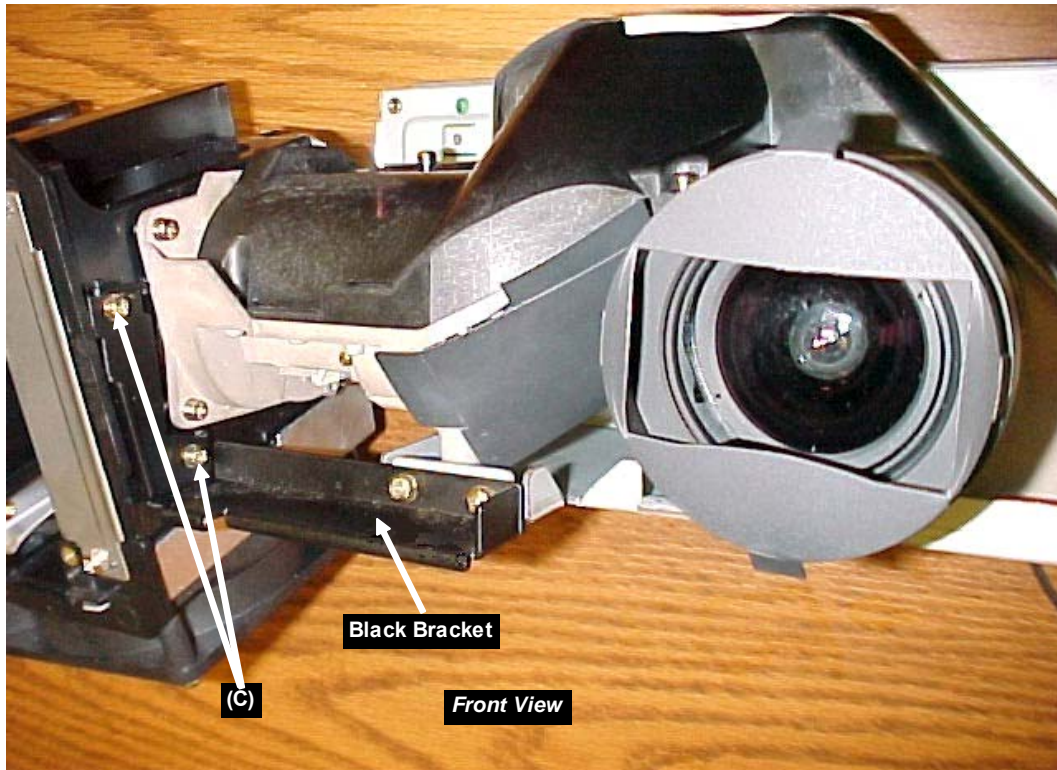

Figure 3: Black Support Bracket

Installing the Optical Engine

- 1) Install the Bottom Plate, Black Support Bracket and the Thermal Sensor from the original Optical Engine, on the replacement Engine
- 2) Reverse the removal procedure to install the replacement Optical Engine in the cabinet.
- 2) The following adjustments may have to be performed after the installation.
 - Horizontal and Vertical Electrical Centering Adjustment.
 - Optical Unit Rotation Adjustment
 - Optical Unit Keystone Distortion Adjustments.

SERVICING THE LENTICULAR SCREEN AND FRESNEL LENS

CAUTION: **Wear gloves** when handling the Lenticular Screen and Fresnel Lens. This prevents cuts and finger prints. **Do not place Fresnel Lens in the sun.** This may cause fire and heat related injuries.

Lenticular Screen and Fresnel Lens Removal

1. Remove the screen assembly shown in the Cabinet Disassembly procedure.
2. Remove the four screws (a) to remove the bottom of the SCREEN-FRAME-BOTTOM . (Figure 1)
3. From the front of the screen assembly, slide the BEZEL out the bottom of the Screen Frame. (Figure 2)
4. From the rear of the screen assembly, carefully slide the Lenticular Screen and Fresnel Lens combination from the Screen Frame. (Figure 3)

Note: When separating the Lenticular Screen from the Fresnel Lens, use caution while prying the Screen and Lens apart. Use a slot type screw driver, and remove the pressure sensitive double sided tape.

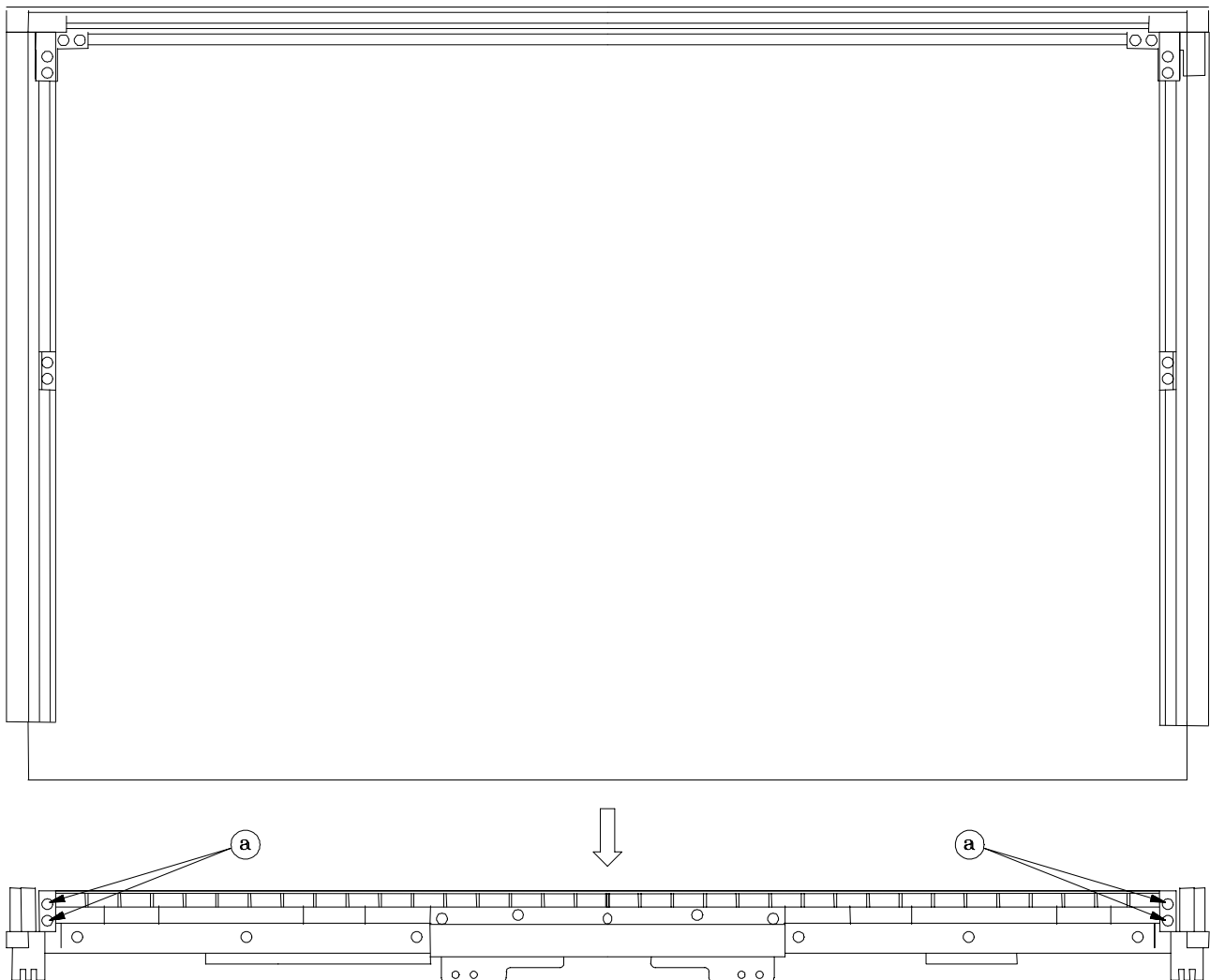

Figure 1: SCREEN-FRAME-BOTTOM Removal (Rear View)

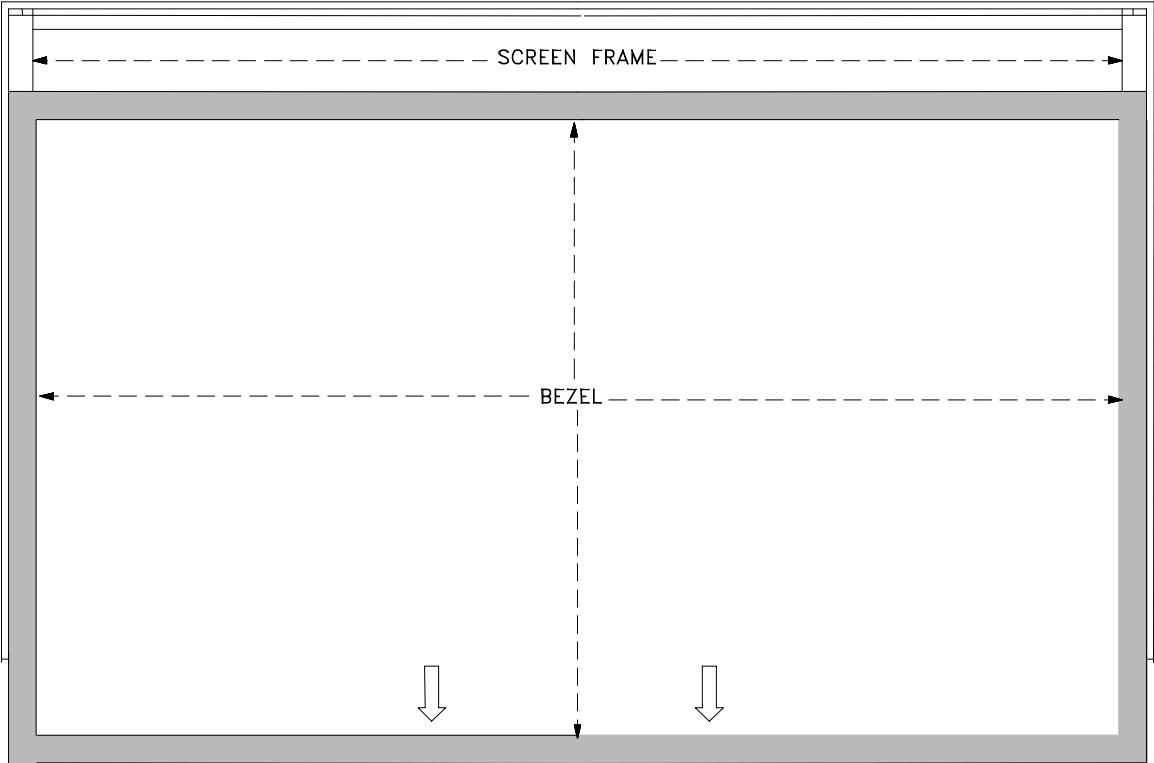

Figure 2: BEZEL Removal (Front View)

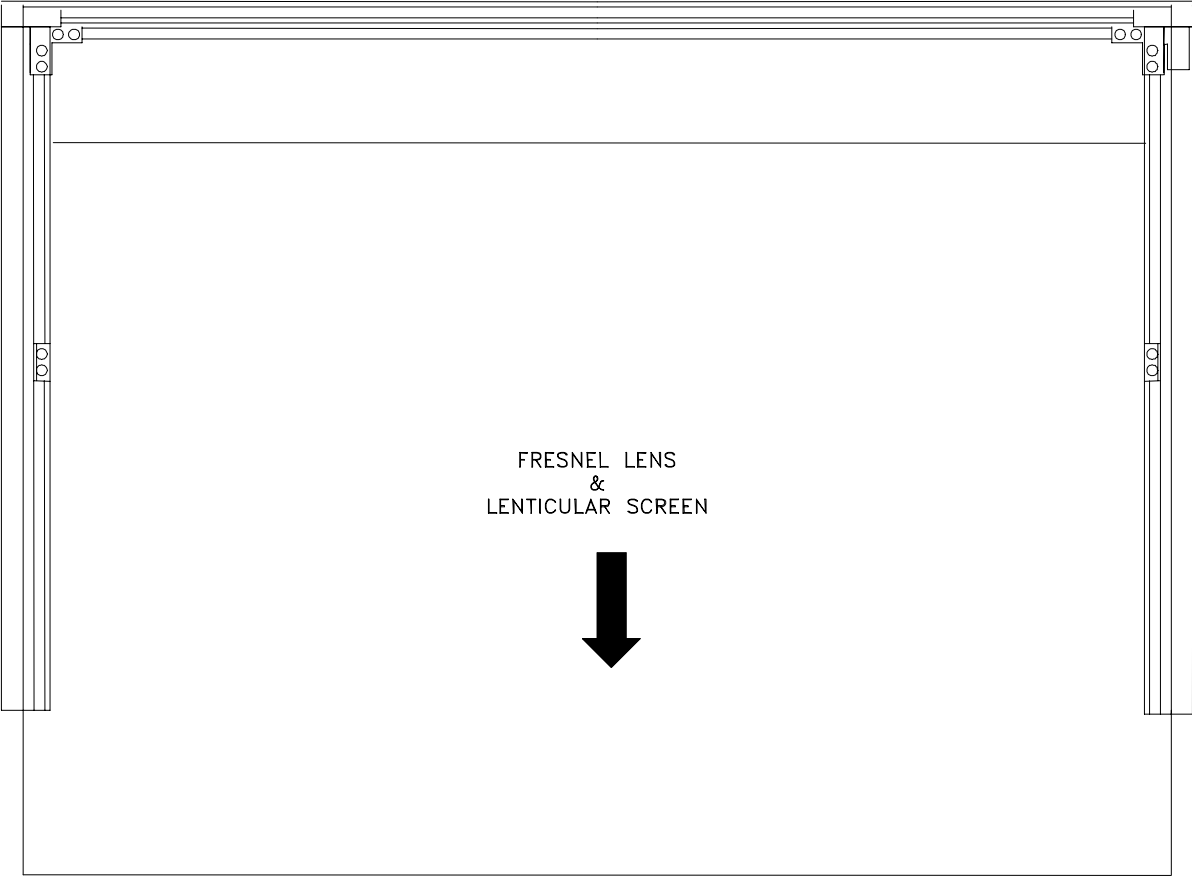

Figure 3: Lenticular Screen & Fresnel Lens Removal (Rear View)

SERVICING THE LENTICULAR SCREEN AND FRESNEL LENS

Lenticular Screen and Fresnel Lens Installation

Note: Store the Lenticular Screen and Fresnel Lens in a cool dry place. High humidity may deform the Lenticular Screen and Fresnel Lens.

1. Apply double coated tape (Part #LENS-TAPE) along the top rear edge of the Lenticular Screen, as shown below. Refer to the table below for the tape length.
2. Sandwich the Fresnel Lens and Lenticular Screen together. The Lenticular Screen label must be towards the front and the Fresnel Lens label towards the rear. (Figure 4)
3. Apply pressure at the top edge to bond the screens together.
4. Reverse the Screen Removal procedure and insert the screens in the Screen Fame Assembly.

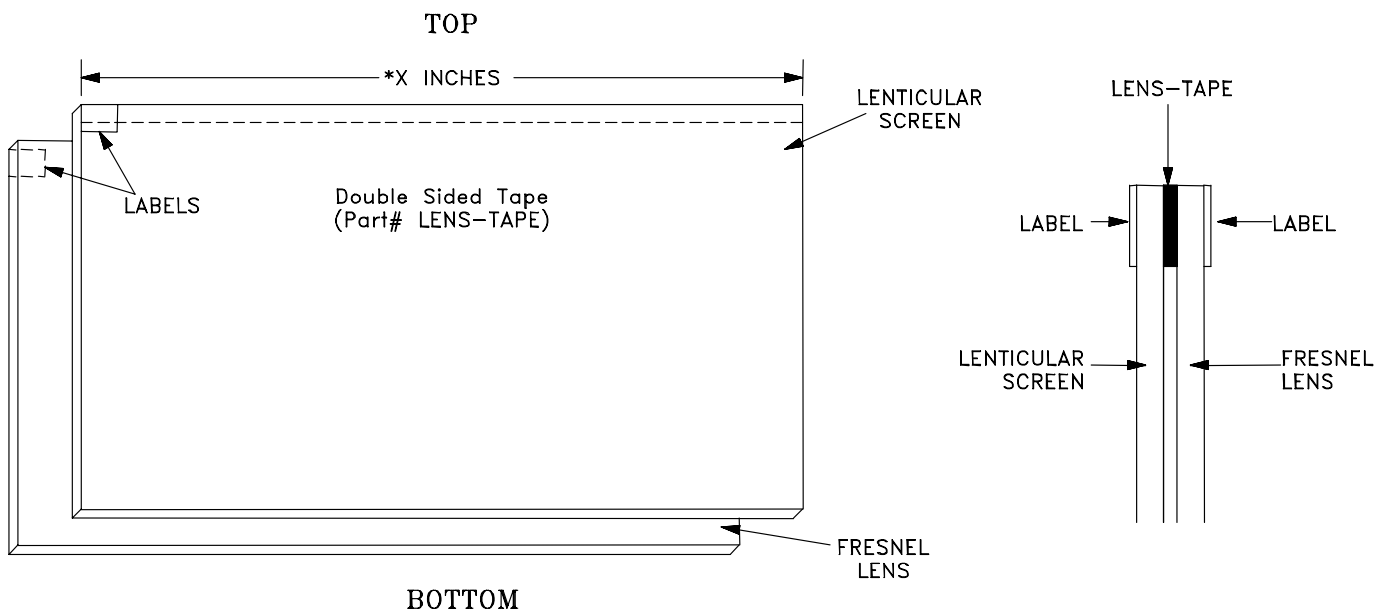

Figure 4: Installing the Fresnel Lens & Lenticular Screen

*X INCHES - Refer to the Tape Length in the table below

MODEL	SCREEN SIZE	TAPE LENGTH
WD-52327	52 Inches	46.3 Inches
WD-62327	62 Inches	55.1 Inches

ELECTRICAL ADJUSTMENTS

Note: Perform only the adjustments required.
Do not attempt an alignment if proper equipment is not available.

Test Equipment

- Oscilloscope (Unless otherwise specified, use 10:1 probes)
- Signal Generator (NTSC Color Bar)

Test Signals

A. Internally Generated Square Pattern Signals

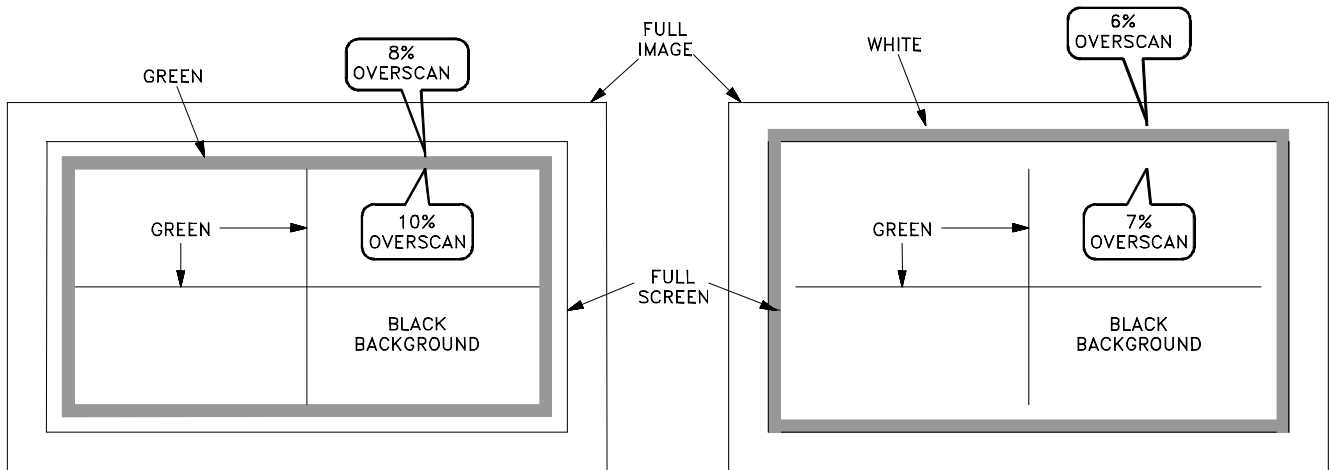

B. Color Bar Signal

Use the color bar signal shown below, unless otherwise specified in this manual.

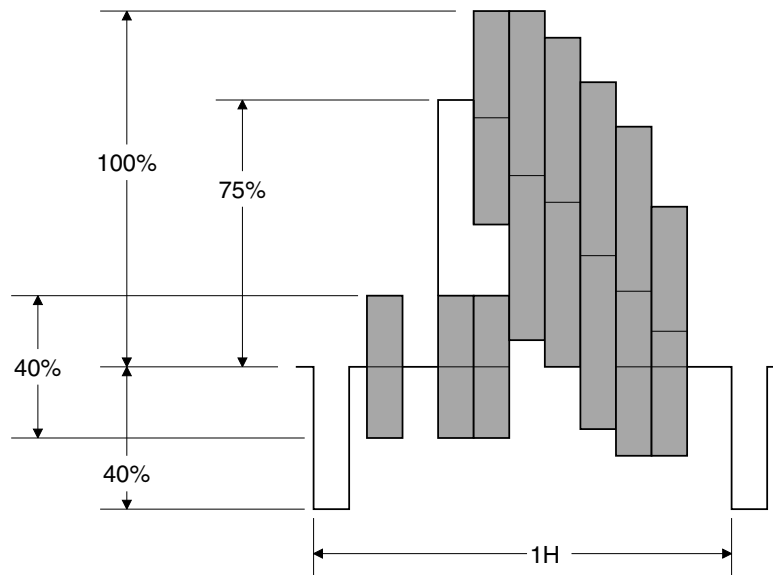

Split-Field Color Bars (100% window)

Initial Setup

A. Option Menu Setup

Follow the steps below for the initial set-up:

1. Select the "MENU" display by pressing the "MENU" button once.
2. Press the number buttons "5", "7", "7", "0" in sequence to select the "OPTION MENU" display.
3. Press the "ADJUST" button to select "INITIALIZE."
4. Press "ENTER."

NOTE: At this time channel 3 is automatically selected.

OPTION MENU <MENU> <5-7-7-0>

Initialize				
Power Restore:	Off			
DTV Port:	AUTO			
Direct Key Mode:	Off			
Lamp Hours:	TOTAL	CURRNT	PREV1	PREV2
	0	0	0	0
	↑	↑	↑	↑
	Total TV On Time	Current Lamp Time	Previous Lamp Time	Previous Lamp Time 2

B. Default Settings

VK26 Main Menu Default Settings

Setup Menu					
Memorize Channels	Ant-A	Unlock Time	N/A	Red	50%
Language	English	Front Button Lock	Off	Yellow	50%
Energy Mode	Standard	V-Chip Menu		Green	50%
Input Assignment Menu		V-Chip	Off	Cyan	50%
Antenna-A	On	TV Rating	TV-PG	Blue	50%
Antenna-B	On	FV-Fantasy Violence	Allow	Audio/Video Settings Menu	
DTV	YPrPb	D-Sexual Dialog	Allow	A/V Memory Reset	Ant-A
Component-1	Comp-1	L-Adult Language	Allow	TV Speakers (internal)	On
Component-2	Comp-2	S-Sexual Situation	Allow	Audio Output	Fixed
Input-1	Input-1	V-Violence	Allow	Audio Settings (TV)	
Input-2	Input-2	Movie Rating	PG	Bass	50%
Input-3	Input-3	Programs Not Rated	Allow	Treble	50%
MonitorLink™	MonoLink	V-Chip Hours		Balance	Center
Clock Menu		V-Chip Start Time	12:00am	Surrond	Off
Clock Setting	Manual	V-Chip Start Time	12:00am	Listen To	Stereo
Clock Time	../..	Advanced Features Menu		Level Sound	Off
Set Day	Sunday	Color Balance		TV Volume	30%
Time Zone	N/A	Timer		Video Settings (TV)	
Daylight Savings	N/A	Video Mute	On	Contrast	50%
Captions		Black Enhancementt	On	Brightness	50%
Closed Captions	In Mute	Color Balance Menu		Sharpness	50%
CC Background	Gray	Ant-A Auto Color Correction	Off	Color	50%
Channel Edit Menu		PerfectColor™		Tint	50%
Antenna	Ant-A	Reset Color for Ant-A		Color Temp.	High
Channel	003	Timer Menu		Video Noise	Standard
Memory	Deleted	Timer	Off	Film Mode (Auto)	On
Name	N/A	Set Time	12:00 AM	PIP Menu	
SQV	N/A	Set Day	Everyday	PIP Souce	Ant-A Ch-3
V-Chip Lock Menu		Input	Ant-A	PIP Position	Lower Rt.
Lock by Time	On	Channel	003	POP Position	Rt. Half
Lock Time	N/A	PerfectColor™		PIP/POP Format	Dble Win.
		Magenta	50%	Format	Stretch

A/V Memory Defaults

Function	Ant -A/B	DTV	Comp-1/2	Input 1/2/3	MonoLink
Contrast	Maximum	Maximum	Maximum	Maximum	Maximum
Brightness	Center	Center	Center	Center	Center
Sharpness	Center	Center	Center	Center	Center
Color	Center	Center	Center	Center	Center
Tint	Center	Center	Center	Center	Center
Color Temp.	High	High	High	High	High
Video Noise	Standard	Standard	Standard	Standard	Standard
Film Mode	On	On	On	On	On
Bass	Center	Center	Center	Center	Center
Treble	Center	Center	Center	Center	Center
Balance	Center	Center	Center	Center	Center
Surround	Off	Off	Off	Off	Off
Listen To	Stereo	N/A	N/A	N/A	N/A
Level Sound	Off	Off	Off	Off	Off

C. A/V Memory

Each of the external inputs has its' own Audio/Video Memory. A change in an A/V setting at a specific input is stored in memory for that specific input.

A/V Reset

1. The front panel AV Reset button initializes all A/V Memories.
2. The AV Reset in the user's menu initializes only the selected input's A/V Memory.

LED Indications

The three front panel LEDs provides an indication of the sets operation, and the possible cause of a malfunction.

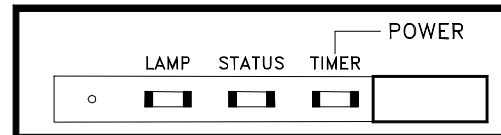

Normal LED Indications

LED			
Power/Timer	Status	Lamp	Condition
Off	Off	Off	Off (standby)
Green Blink	Off	Off	µPC Initializing (after AC off/on) (1~2 sec)
Off	Off	Blink green	Lamp Fan running (1 min after PTV Off)
Green	Off	Off	Power On
Slow Green Blink	Off	Off	Power On Timer is set.

Abnormal LED Indications

LED			
Power/Timer	Status	Lamp	Condition
Off	Yellow	Off	Temp. high - dirty filter/excess room temp.
Off	Off	Yellow	4000 hrs. Lamp usage warning
Off	Off	Blink Yellow	Lamp Cover open
Off	Blink Yellow	Off	Air Filter Cover open
Off	Off	Red	Lamp failure (failed to turn On or broken)
Off	Blink Red	Off	Fan Stopped
	Red	Off	Circuit failure (short) or DVI cable disconnected

LED Diagnostic Check

1. Initial Control Circuitry Check

Immediately after the TV is connected to an AC power source:

2. Error Code Operational Check

Pressing the front panel "INPUT" and "MENU" buttons at the same time, and holding for 5 seconds, activates the Error Code Mode. The "Power LED" flashes denoting a two digit Error Code, or indicating no problem has occurred since the last Initialization.

Note: The front panel buttons must be used, NOT those on the Remote Control.

- The number of flashes indicates the value of the MSD (tens digit) of the Error Code.
- The flashing then pauses for approximately 1/2 second.
- The LED then flashes indicating the value of the LSD (ones digit) of the Error Code.
- The Error Code is repeated a total of 5 times.

Example: If the Error Code is "34", the LED will flash 3 times, pause, and then flash 4 times.

3. Error Codes

The Error Code designations indicating a malfunction, or no malfunction, are listed below:

ERROR CODES

Error Code	Description
12	No Error detected, check Power Supply
32	Lamp Cover is open
33	Air Filter Cover is open
34	Lamp abnormality
36	Light Engine (DMD or LAMP Fan stopped)
37	Exhaust or Lamp Ballast Fan stopped
38	Lamp temperature high
39	DMD temperature high
41	Short is detected
44	DVI cable between FMT & Engine disconnected.

Circuit Adjustment Mode

Most of the adjustments can only be performed using the remote hand unit.

A. Activating the Circuit Adjustment Mode

1. Select the signal source.
2. Press the "MENU" button on a remote hand unit.
3. Press the number buttons "5", "7", "5", "7" in sequence. The screen will change to the Adjustment Mode.

Note: Repeat steps 1 and 2 if the circuit adjustment mode does not appear on screen.

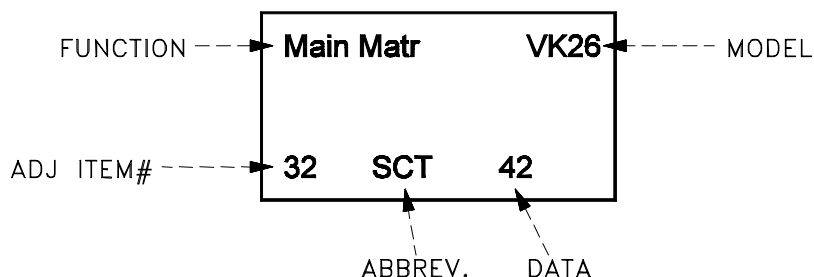

B. Selection of adjustment Functions and Adjustment Items

To select an adjustment item in the circuit adjustment mode, first select the adjustment function that includes the specific item to be adjusted. Then select that adjustment item.

Refer to the following pages for the listing of adjustment functions and adjustment items.

1. Press the "AUDIO" button on a remote hand unit to select an adjustment function. Each time the button is pressed, the Function changes in the following sequence:

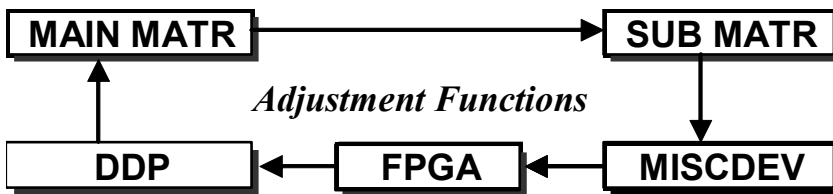

2. Press the "VIDEO" button to select a specific Adjustment Item. The Item number increases each time the "VIDEO" button is pressed.

C. Changing Data

After selecting an adjustment Item, use the "ADJUST UP/DOWN" buttons to change data.

- Press "ADJUST DOWN" to decrease the data value.
- Press "ADJUST UP" to increase the data value.

D. Saving Adjustment Data

Press "ENTER" to save adjustment data in memory. The character display turns red for approximately one second in this step.

Note: If the circuit adjustment mode is terminated without pressing "ENTER", changes in adjustment data are not saved.

E. Terminating the Circuit Adjustment Mode

Press the "MENU" button on the remote hand unit twice to terminate the adjustment mode.

Note: The circuit adjustment mode can also be terminated by turning power OFF.



List of Service Adjustment Items

MAIN MATRIX

(Main Decoder)

Stored in IC2K02 on PWB-TERMINAL

Item No.	Abbrev.	Description	Data Range	Initial Data
39	SCNT	Main Y-Gain	0~31	16
41	SCLR	Main CB/CR Gain	0~31	22

SUB MATRIX

(Sub Decoder)

Stored in IC2K02 on PWB-TERMINAL

Item No.	Abbrev.	Description	Data Range	Initial Data
39	SCNT	Sub Y-Gain	0~31	15
41	SCLR	Sub CB/CR Gain	0~31	21

FPGA

Stored in IC7C01 on PWB-SIGNAL

Item No.	Abbrev.	Description	Data Range	Initial Data
1	H-DLY	Horiz. Position	0~128	74
2	V-DLY	Vertical Position	0~55	32

DDP Function

Stored in IC2K02 on PWB-TERMINAL

Item #	Abbrev.	Description	Data Range	Initial Data	
				WD-52327	WD-62327
120	GGH	High Temp. Green Gain	000~400	2FA	31F
121	GRH	High Temp. Red Gain	"	400	400
122	GBH	High Temp. Blue Gain	"	36D	34F
123	GGM	Mid Temp. Green Gain	"	2E1	2FE
124	GRM	Mid Temp. Red Gain	"	400	400
125	GBM	Mid Temp. Blue Gain	"	320	2FF
126	GGL	Low Temp. Green Gain	"	2C8	2EC
127	GRL	Low Temp. Red Gain	"	400	400
128	GBL	Low Temp. Blue Gain	"	2D4	2C0

NOTE: Data values are in hexadecimal format

Activating & Selecting an Internal Test Signal

1. Select an External Input with no signal.
2. Press the buttons "MENU"-**"5"**-**"7"**-**"5"**-**"7"** in sequence. (Activates the Service Menu)
3. Select the "FPGA" function (AUDIO button)
4. Press "1" for Pattern A, or "2" for Pattern B.
5. **Press "9"** to return to the Service Menu.
6. Press "MENU" to exit the Service Mode.

CAUTION

DO NOT press "MENU" (or HOME) without pressing "9" first. (The Video Mute function will not function properly.)

To correct the Mute function -- remove AC to the TV, then reapply AC to reset the unit.

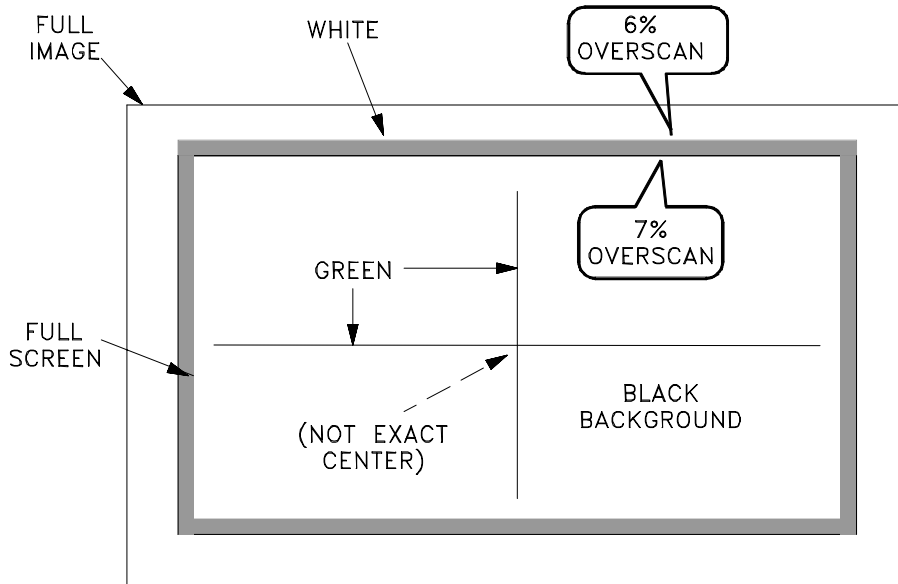

Pattern A

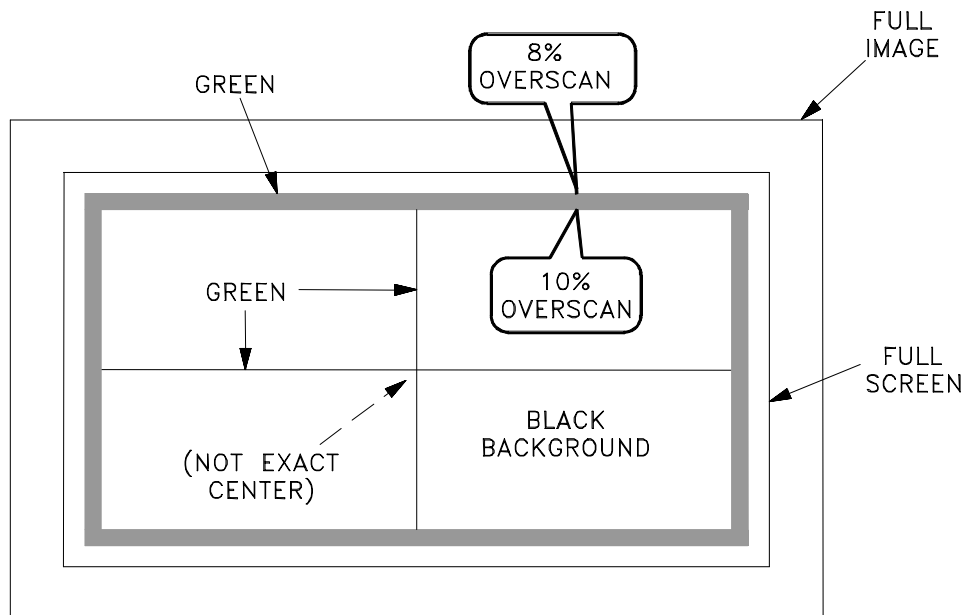

Pattern B

MODEL: WD-52327 / WD-62327

[Video Circuit]		Purpose: To set picture luminance
1. Main/Sub Y Level		Symptom: Excess or insufficient brightness.
Measuring Instrument	Oscilloscope	<ol style="list-style-type: none"> 1. Supply a color bar signal to a Video Input (not an RF input). 2. Select the color bar signal for both the main and sub pictures. 3. Connect the oscilloscope to connector JA pin 22. (Main-Y) 4. Activate the Adjustment Mode (MENU-5-7-5-7) 5. Select the "MAIN MTRX" function. (AUDIO button) 6. Select adjustment Item "39 SCNT". (VIDEO button) 7. Adjust the data for 0.71 ~ 0.76 Vp-p at JA pin 22. (If it cannot be adjusted within this range, set to the lower value) 8. Move the oscilloscope to connector JB pin 3. (Sub-y) 9. Select the "SUB MTRX" function. (AUDIO button) 10. Select adjustment Item "39 SCNT". (VIDEO button) 11. Adjust the data to equal the MAIN-Y Gain (+0.0V -0.05V). 12. Press "ENTER" to save data changes.
Test Point	JA-22 & JB-3	
Ext. Trigger	-----	
Measuring Range	-----	
Input Signal	Color Bars	
Input Terminal	Video Input	

CIRCUIT ADJUST MODE

Activate MENU-5-7-5-7
 FunctionAUDIO
 Item No.VIDEO
 Adjust DataADJUST
 Save DataENTER
 ExitMENU (twice)

REAR (TOP VIEW)

The diagram shows the rear panel with two connectors, JA and JB, each containing 16 pins. Pin 20 is on the left of JA, pin 22 is on the right of JA. Pin 3 is on the left of JB, pin 5 is on the right of JB. A PWB-SIGNAL line runs above the connectors. A PWB TERMINAL is located to the right of the JB connector. The panel is shielded, with terminal-pwb shield and openings in the shield indicated.

[Video Circuit]		Purpose: To set the sub picture color level.
2. Main/Sub Color Level		Symptom: Main and sub pictures color levels differs.
Measuring Instrument	Oscilloscope	<ol style="list-style-type: none"> 1. Supply a color bar signal to a Video Input. 2. Select the color bar signal as the source for both the main and sub picture. 3. Connect an oscilloscope to connector JA pin 20 (main Cr). 3. Activate the Adjustment mode (MENU-5-7-5-7) 4. Select the "MAIN MTRX" function (AUDIO button). 5. Select adjustment item "41 SCLR" (VIDEO button) 6. Adjust the data for 0.81 ~ 0.86 Vp-p min. at JA pin 20. (If it cannot be adjusted within this range, set to the lower value). 7. Move the oscilloscope to connector JB pin 5 (sub Cr). 8. Select the "SUB MTRX" function (AUDIO button). 9. Select adjustment item "41 SCLR" (VIDEO button). 10. Adjust data so the Sub Cr amplitude equals that of the Main Cr. 11. Press "ENTER" to save data changes.
Test Point	JA-20 & JB-5	
Ext. Trigger	-----	
Measuring Range	200mV/div 20usec/div	
Input Signal	Color Bars	
Input Terminal	Video Input	

REAR (TOP VIEW)

The diagram is identical to the one in the first section, showing the rear panel with connectors JA and JB, PWB-SIGNAL, PWB TERMINAL, and shield openings.

The timing diagram shows two waveforms. The first waveform, labeled 'MAIN PICTURE', is a square wave with a higher amplitude. The second waveform, labeled 'SUB PICTURE', is a square wave with a lower amplitude. The two waveforms are shown side-by-side, indicating their relative timing and amplitudes.

<p>[Video Circuit]</p> <p>3. White Balance</p>	<p>Purpose: To set high, mid and low temperature white levels.</p> <p>Symptom: White areas have a color tint.</p>												
<table border="1" style="width: 100%; border-collapse: collapse;"> <tr> <td style="width: 15%;">Measuring Instrument</td> <td></td> </tr> <tr> <td>Test Point</td> <td></td> </tr> <tr> <td>Ext. Trigger</td> <td>-----</td> </tr> <tr> <td>Measuring Range</td> <td>-----</td> </tr> <tr> <td>Input Signal</td> <td>White Raster</td> </tr> <tr> <td>Input Terminal</td> <td>Video Input</td> </tr> </table>	Measuring Instrument		Test Point		Ext. Trigger	-----	Measuring Range	-----	Input Signal	White Raster	Input Terminal	Video Input	<ol style="list-style-type: none"> 1. Supply a 100% white raster to an External Video Input. 3. Activate the Service Mode. (MENU-5-7-5-7) 4. Select the "DDP" function. (AUDIO button) 5. Select adjustment Items with the VIDEO button. <p>NOTE: Data is displayed in the hexadecimal format.</p> <ol style="list-style-type: none"> 6. Adjust the data for Items "120 GGH", "121 GRH" and "122 GBH" for optimum white at the center of the screen. 7. Adjust the data for Items "123 GGM", "124 GRM" and "125 GBM" for optimum white at the center of the screen. 8. Adjust the data for Items "126 GGL", "127 GRL" and "128 GBL" for optimum white at the center of the screen. 9. Press "ENTER" to save data changes. 10. Press "MENU" twice to exit the Service Mode.
Measuring Instrument													
Test Point													
Ext. Trigger	-----												
Measuring Range	-----												
Input Signal	White Raster												
Input Terminal	Video Input												
<div style="border: 1px solid black; padding: 5px; margin-top: 10px;"> <p>CIRCUIT ADJUST MODE</p> <p>Activate MENU-5-7-5-7</p> <p>FunctionAUDIO</p> <p>Item No.VIDEO</p> <p>Adjust DataADJUST</p> <p>Save DataENTER</p> <p>ExitMENU (twice)</p> </div>													

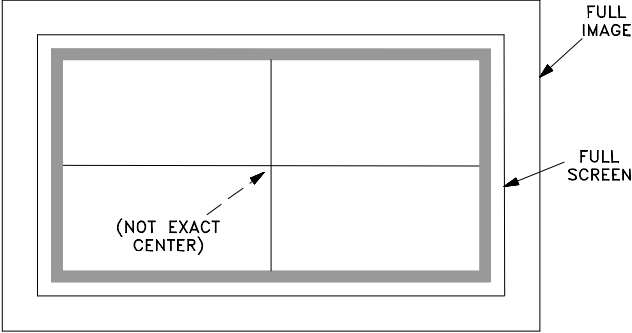
<p>[PICTURE POSITION]</p> <p>4. Horizontal/Vertical Position</p>	<p>Purpose: To center picture on the screen.</p> <p>Symptom: Picture is off center.</p>												
<table border="1" style="width: 100%; border-collapse: collapse;"> <tr> <td style="width: 15%;">Measuring Instrument</td> <td>----</td> </tr> <tr> <td>Test Point</td> <td>----</td> </tr> <tr> <td>Ext. Trigger</td> <td>-----</td> </tr> <tr> <td>Measuring Range</td> <td>-----</td> </tr> <tr> <td>Input Signal</td> <td>Internal Pattern "B"</td> </tr> <tr> <td>Input Terminal</td> <td>External Input</td> </tr> </table>	Measuring Instrument	----	Test Point	----	Ext. Trigger	-----	Measuring Range	-----	Input Signal	Internal Pattern "B"	Input Terminal	External Input	<p>NOTE: The TV must be on a flat level surface.</p> <ol style="list-style-type: none"> 1. Select an External Input with no signal. 2. Press "MENU-5-7-5-7" in sequence (activates the Service Mode). 3. Press "AUDIO" to select the "FPGA" function. 4. Press "2" to activate internal Test Pattern B. (Shown below) 5. Use the "VIDEO" button to select Item "1 H-DLY". 6. Use the "ADJUST" buttons to center the picture Horizontally.. 7. Press "ENTER" to save the adjustment. 8. Use the "VIDEO" button to select Item "2 V-DLY". 9. Use the "ADJUST" buttons to center the picture Vertically. 10. Press "ENTER" to save the adjustment. 11. Press "9" to terminate the test pattern. 12. Press "Menu" twice to terminate the Adjustment Mode.
Measuring Instrument	----												
Test Point	----												
Ext. Trigger	-----												
Measuring Range	-----												
Input Signal	Internal Pattern "B"												
Input Terminal	External Input												
<div style="text-align: center; margin-top: 20px;">  <p>Pattern B</p> </div>	<div style="border: 1px solid black; padding: 5px; margin-top: 10px;"> <p>CIRCUIT ADJUST MODE</p> <p>Activate MENU-5-7-5-7</p> <p>FunctionAUDIO</p> <p>Item No.VIDEO</p> <p>Adjust DataADJUST</p> <p>Save DataENTER</p> <p>Exit "9" then "MENU"</p> </div>												

Mechanical Adjustments

- To perform the mechanical adjustments, **the TV must be on a flat level surface** and a certain amount of disassembly is required.
- Use internal Test Pattern B for all mechanical adjustments.

Front Disassembly

Refer to the diagram below for the Front Panel removal procedures.

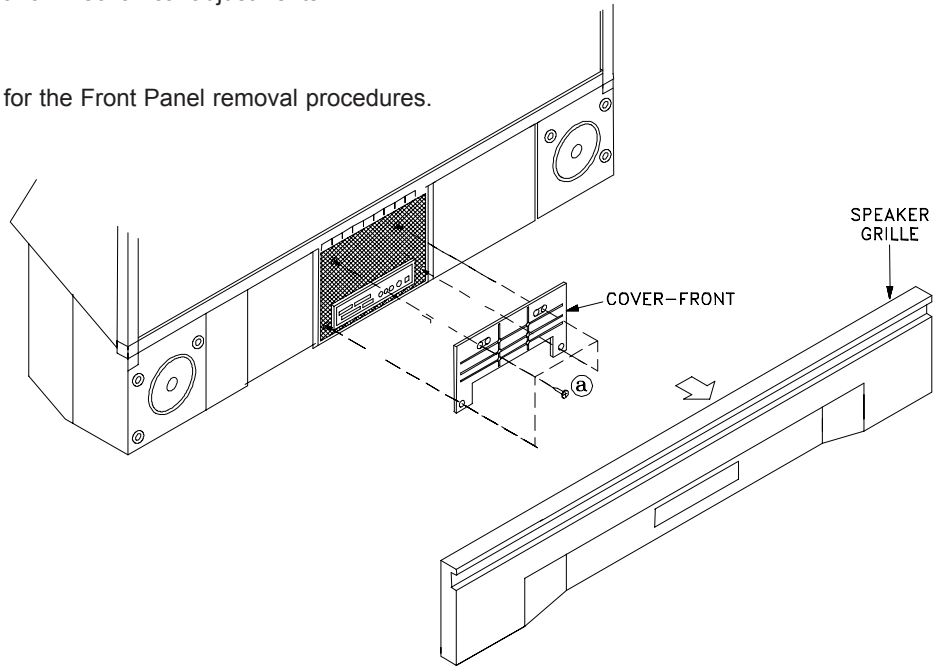

Rear Disassembly

Refer to the to the diagrams below for the COVER-BACK and Rear Plate removal.

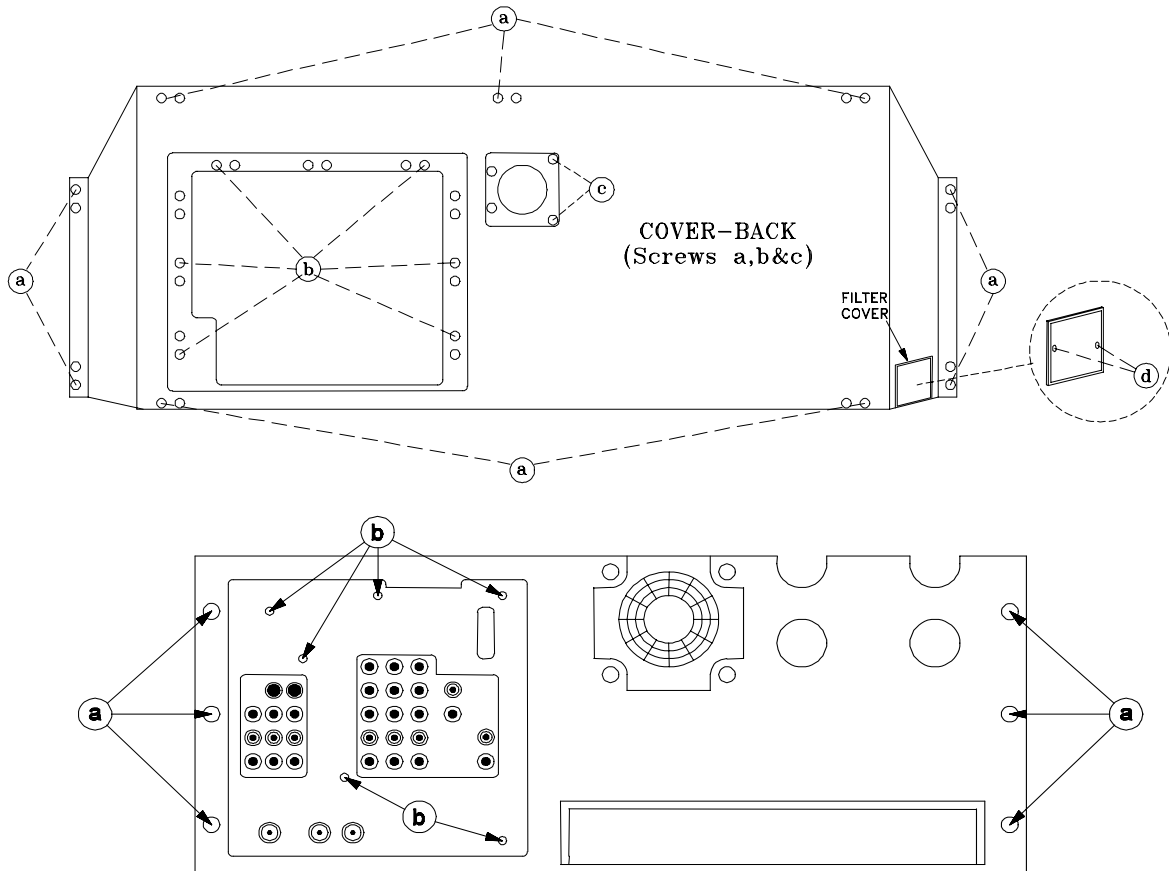

NOTE: To operate the TV with the COVER-BACK removed, the FILTER-COVER must be reinstalled and the Exhaust Fan connected.

Picture Rotation Adjustment

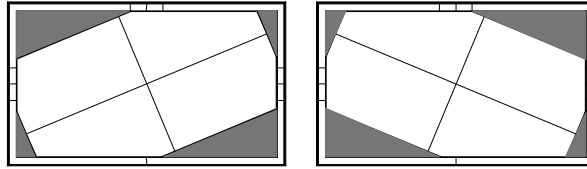

NOTE: The TV must be on a flat level surface.

1. From the front of the TV, lift the foam to access and loosen slightly, the brass Rotation Locking Screws on the Adjuster Assembly, *Figure 4A*. (Use a 10mm wrench.)
2. From the rear of the TV, access the black Rotation Adjustment screw and adjust so the test pattern center lines are parallel to the sides, top and bottom of the screen frame, *Figure 4B*. (Use a mirror to view the picture from the rear of the set.)
3. Tighten the two Locking Screws. Use Locktite to secure the Adjustment Screw. (If necessary, use the electrical adjustments to center the picture)

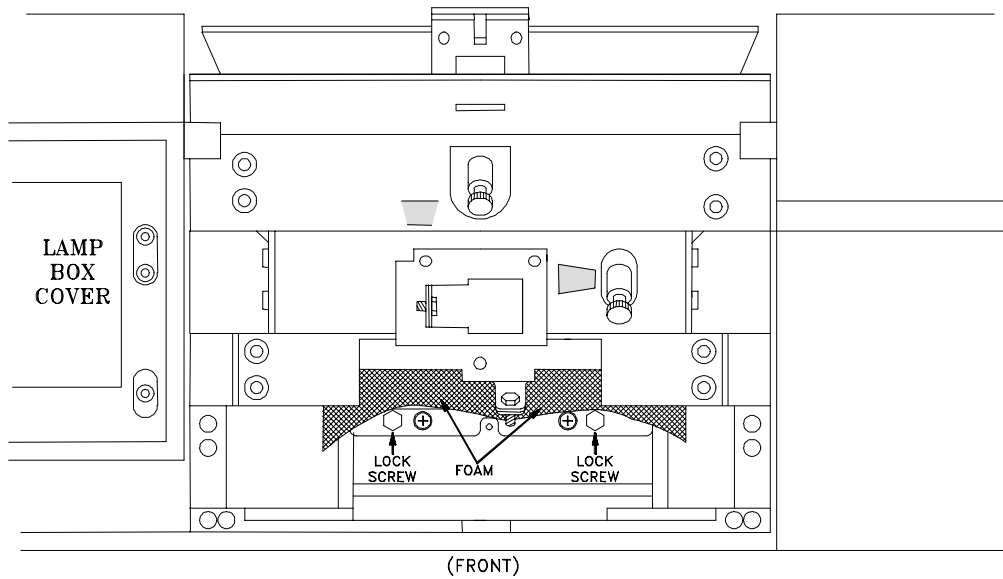

Figure 4A: Rotation Adjustment Lock Screws

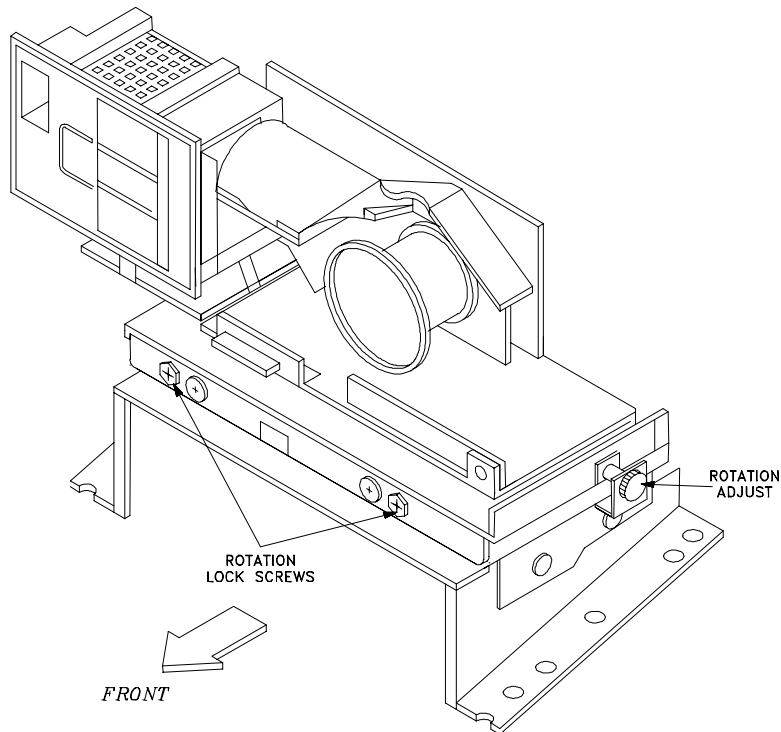
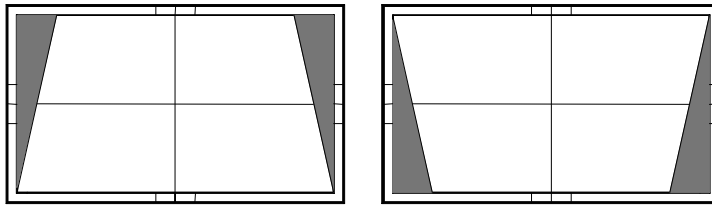
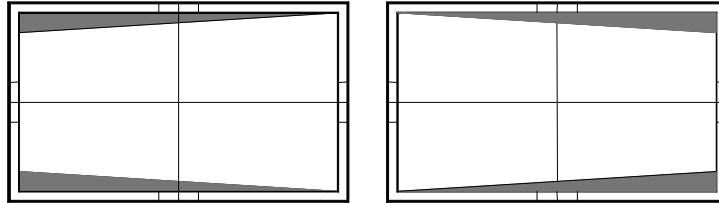

Figure 4B: Rotation Adjustment Location

Keystone Adjustment



Horizontal Keystone Distortion



Vertical Keystone Distortion

NOTE: The TV must be on a flat level surface

1. From the front of the TV, loosen the two Keystone Locking Screws in the small mirror assembly. (10mm wrench)
2. From the front of the TV, adjust the Horizontal Keystone Adjustment for minimum distortion.
3. From the front of the TV, adjust the Vertical Keystone Adjustment for minimum distortion.
4. Tighten the Keystone Lock Screws. and secure the adjustment screws with Locktite. (If necessary, use the electrical adjustments to center the picture)

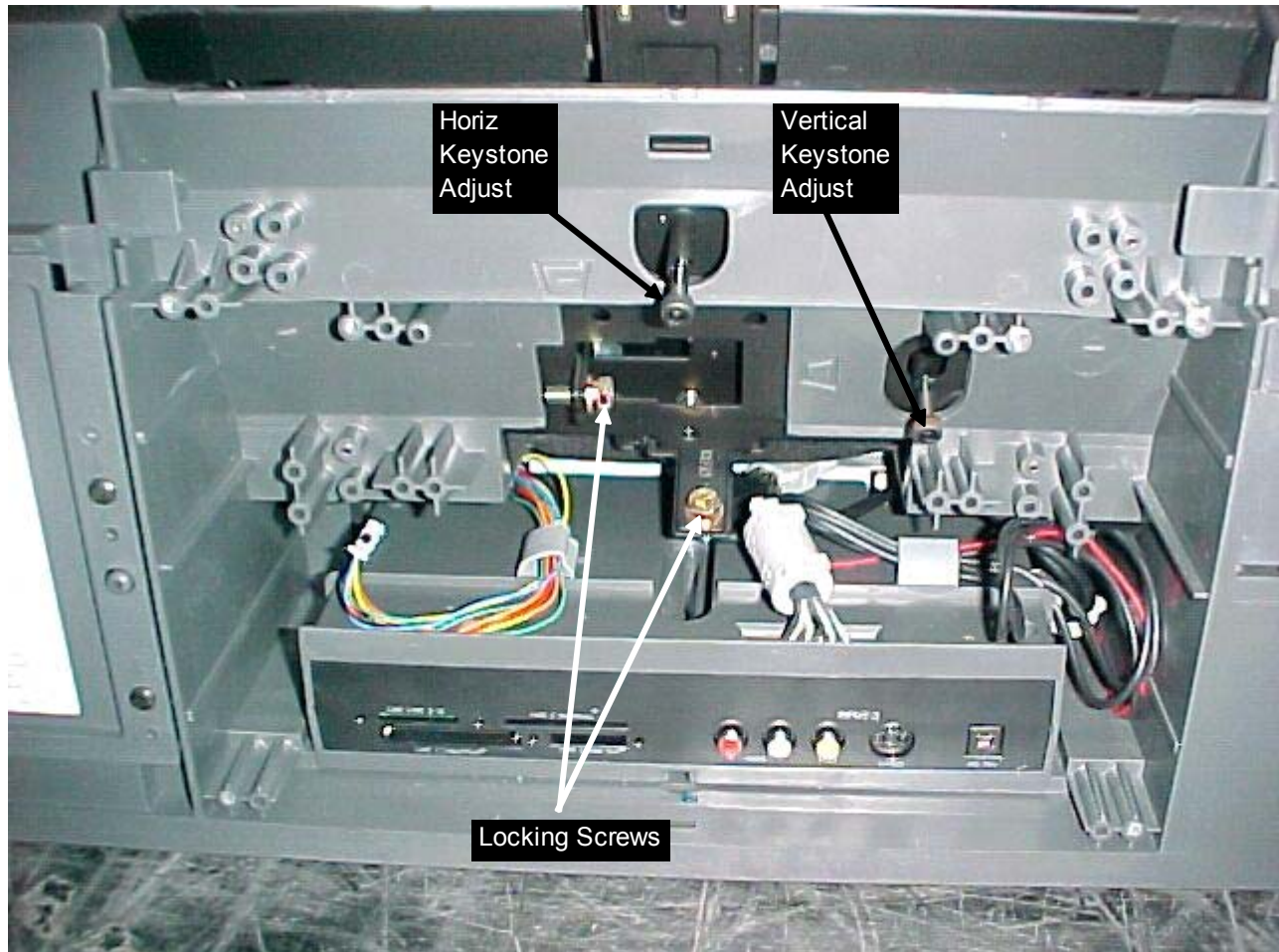

Small Mirror Assembly (Front View)

QUICK REFERENCE FOR COMMON REPLACEMENT PARTS

- **Critical Electrical Components** are indicated by **Bold Type** in the Parts List

Customer Replaceable Parts

Part Name	Description	WD-52327	WD-62327
Lamp Cartridge	LAMP-CARTRIDGE	915P020010	915P020010
Dust Filter	FILTER-DUST	620D144010	620D144010
Remote Control	REMOTE	260P116010	260P116010

Service Parts

Part Name	Description	WD-52327	WD-62327
Optical Engine	OPTICAL-ENGINE	939P977010	939P977020
Lamp Ballast	UNIT-POWER-LAMP	939B978010	939B978010
Power PWB	ASSY-PWB-POWER	930B929001	930B929001
Signal PWB	ASSY-PWB-SIGNAL	930B930001	930B930001
Format PWB	ASSY-PWB-FMT	930B931001	930B931001
Terminal PWB	ASSY-PWB-TERMINAL	930B932001	930B932001
Sub Power PWB	ASSY-PWB-POWER-SUB	934C148001	934C148001
Audio PWB	ASSY-PWB-AUDIO	934C149001	934C149001
Remote Preamp	ASSY-PWB-PREAMP	935D811001	935D811001
Front PWB	ASSY-PWB-FRONT	935D812001	935D812001
Control PWB	ASSY-PWB-CONTROL	935D813001	935D813001
Right Speaker PWB	ASSY-PWB-SPEAKER-R	935D814001	935D814001
Left Speaker PWB	ASSY-PWB-SPEADER-L	935D815001	935D815001
Lamp Fan	FAN-LAMP	299P282010	299P282010
DMD Fan	FAN-DMD	299P283010	299P283010
Ballast Fan	FAN-BALLAST	299P278020	299P278020
Exhaust Fan	FAN-EXHAUST	299P103050	299P103050
DMD Thermal Sensor	SENSOR-THERMAL	299P280010	299P280010
Lamp Cover Detect Switch	SW-MICRO	436P021010	436P021010
Filter Cover Detect Switch	SW-MICRO	436P021010	436P021010

Screen Parts

Part Name	Description	WD-52327	WD-62327
Lenticular Screen	LENS-LENTICULAR	491P176030	491P176040
Fresnel Lens	LENS-FRESNEL	491P175010	491P175020
Bezel	BEZEL-FRONT	761A252010	761A253010

MODEL: WD-52327 / WD-62327

Model Legend: [a] WD-52327, [b] WD-623275

Ref #	Part #	Part Name & Description	[#]
INTEGRATED CIRCUITS			
IC2D00	270P974010	IC-C-MOS - SII907B	
IC2D02	261P135010	FET-HEX - IRF7313	
IC2D04	271P004010	IC - CM1208-08MS	
IC2K01	270P623010	IC - CXA2069Q	
IC2K02	275P533010	IC-C-MOS - M24C64WM6T	
IC2K04	275P718010	IC-C-MOS - TC74HC4053FT	
IC2K05	275P718010	IC-C-MOS - TC74HC4053FT	
IC2L01	275P937010	IC-C-MOS - MM1519XQ	
IC2M01	275P947010	IC-C-MOS - UPD64083	
IC2M02	270P992020	IC - BA25BC0FP	
IC2MD1	272P379020	IC - LM1881MX (NSC)	
IC2N01	275P938010	IC-C-MOS - TA1340F	
IC2P01	275P938010	IC-C-MOS - TA1340F	
IC2R01	271P005020	IC - AN15851AN	
IC3A01	275P731020	IC-C-MOS - MSP3445G-QI-B8-V3	
IC3E00	271P080010	IC - TDA8922J	
IC3J01	270P838010	IC-C-MOS - NJM2520M	
IC3J02	270P838010	IC-C-MOS - NJM2520M	
IC3J03	270P838010	IC-C-MOS - NJM2520M	
IC3J04	270P838010	IC-C-MOS - NJM2520M	
IC7A00	276P017070	IC-C-MOS - M306V7FGFP-VK26	
IC7A02	270P706020	IC - MAX823REUK	
IC7A03	275P786010	IC-C-MOS - TC7SA08FU	
IC7A05	271P023010	IC - SN74CBTD1G125DBVR	
IC7A06	271P023010	IC - SN74CBTD1G125DBVR	
IC7AAA	275P981010	IC-C-MOS - 24LCS22AT/SN	
IC7C01	275P533010	IC-C-MOS - M24C64WM6T	
IC7D01	275P278010	IC-C-MOS - TC74LVX14FT	
IC7D02	270P818020	IC - CXA3506R	
IC7D03	267P172010	HIC - AF-9395A	
IC7E00	275P451010	IC-C-MOS - TC74HC4066AFN	
IC7E01	275P560010	IC-C-MOS - ADS931E	
IC7E02	275P560010	IC-C-MOS - ADS931E	
IC7E03	275P560010	IC-C-MOS - ADS931E	
IC7H00	275P963010	IC-C-MOS - DPM5	
IC7H07	270P992010	IC - BA18BC0FP	
IC7M00	275P982010	IC - MT48LC2M32B2-7	
IC7N01	270P348010	IC - TLC2932IPW	
IC7N11	275P236020	IC-C-MOS - TC74LVX244FT	
IC7N21	275P769010	IC-C-MOS - TC74AC157FT	
IC7N31	275P769010	IC-C-MOS - TC74AC157FT	
IC7N41	274P901010	IC-C-MOS - TC74HCT7007AF	
IC7N61	274P901010	IC-C-MOS - TC74HCT7007AF	
IC8C03	275P689010	IC-C-MOS - ICS551MT	
IC8D01	271P112010	IC - IP00C722	
IC8D02	275P982010	IC - MT48LC2M32B2-7	
IC8E00	276P107010	IC-C-MOS - Sii164	
IC8E02	270P879030	IC - SC1566I5M-2.5TR	
IC8E03	270P879030	IC - SC1566I5M-2.5TR	
IC8E04	271P010010	IC - RT9172-18CG	
IC8E05	271P010010	IC - RT9172-18CG	
IC8H01	271P113010	IC - XC2S50E-6PQ208C	
IC8H02	271P114020	IC - XCF01SVO20C-K261	
IC9A10	267P175010	HIC - STR-W6735	
IC9A12	271P081010	IC - BA00CC0WFP	
IC9A20	270P816010	IC - NJM431L	
IC9A21	270P991010	IC - IRU3037CS	
IC9AAA	270P677010	IC - BA033FP	

Ref #	Part #	Part Name & Description	[#]
IC9C01	270P928010	IC - BA17809FP	
IC9C11	270P928010	IC - BA17809FP	
IC9C20	267P164010	HIC - TNY264P	
IC9C21	270P677010	IC - BA033FP	
IC9C21	270P816010	IC - NJM431L	
IC9C31	270P999010	IC - NJM2370R09	
IC9C61	270P677010	IC - BA033FP	
TRANSISTORS			
CHIP Type Transistors (Listed by Part No.)			
	Part No.	Description	
	260P806010	DTA124EK/UN2112	
	260P817010	2SA1037K-Q	
	260P817050	2SA1037K-R,S/2SB709AI-R,S	
	260P817080	2SA1037K-R,S	
	260P818010	2SC2412K-Q	
	260P818050	2SC2412K-R,S/2SD601AI-R,S	
	260P835030	2SC2413K-Q	
	260P846030	DTC143ZKAT146	
TRANSISTORS			
Conventional Transistors (By Ref #)			
Ref #	Part #	Part Name & Description	
Q9A20	261P135010	FET-HEX - IRF7313	
Q9A70	261P101010	TR - PHP21N06T	
Q9B70	261P101010	TR - PHP21N06T	
DIODES			
D2J91	262P075010	DIODE - RSB6.8S	
D7A00	264P828010	D-CHIP - DAN202U/MA142WK	
D7AAA	262P805050	D-CHIP - UDZS5.1B	
D7L20	262P075010	DIODE - RSB6.8S	
D7L21	264P212020	D-LED - LN31GPH	
D7L22	264P584020	DIODE-LE - SML1216W-C,D	
D7L23	264P584020	DIODE-LE - SML1216W-C,D	
D7L24	262P075010	DIODE - RSB6.8S	
D7L25	262P075010	DIODE - RSB6.8S	
D7L26	262P075010	DIODE - RSB6.8S	
D7L27	262P075010	DIODE - RSB6.8S	
D9A00	262P031010	DIODE - D6SB80	
D9A01	262P031010	DIODE - D6SB80	
D9A02	264P045080	DIODE - 1S2076A/1S2471OM	
D9A03	264P461050	DIODE - EQA02-06B/RD5.6EB3	
D9A04	264P045080	DIODE - 1S2076A/1S2471OM	
D9A05	264P899010	DIODE - BYV26E	
D9A06	264P045080	DIODE - 1S2076A/1S2471OM	
D9A18	264P045080	DIODE - 1S2076A/1S2471OM	
D9A19	264P045080	DIODE - 1S2076A/1S2471OM	
D9A20	264P045080	DIODE - 1S2076A/1S2471OM	
D9A23	264P045080	DIODE - 1S2076A/1S2471OM	
D9A24	264P045080	DIODE - 1S2076A/1S2471OM	
D9A25	264P045080	DIODE - 1S2076A/1S2471OM	
D9A26	262P066010	DIODE - RU4A	
D9A27	262P066010	DIODE - RU4A	
D9A28	264P045080	DIODE - 1S2076A/1S2471OM	
D9A29	264P045080	DIODE - 1S2076A/1S2471OM	
D9A30	264P470070	DIODE - EQA02-32B/RD33EB3	
D9A31	264P828010	D-CHIP - DAN202U/MA142WK	
D9A32	264P828010	D-CHIP - DAN202U/MA142WK	

MODEL: WD-52327 / WD-62327

[#] Model Legend: [a] WD-52327, [b] WD-62327

Ref #	Part #	Part Name & Description	[#]
D9A33	264P458050	DIODE - RD3.9EB1	
D9A34	262P090010	DIODE - M1FP3	
D9A41	264P828010	D-CHIP - DAN202U/MA142WK	
D9A42	264P828010	D-CHIP - DAN202U/MA142WK	
D9A43	264P828010	D-CHIP - DAN202U/MA142WK	
D9A44	264P828010	D-CHIP - DAN202U/MA142WK	
D9A45	264P828010	D-CHIP - DAN202U/MA142WK	
D9A60	264P669030	DIODE - S3L20U	
D9A61	264P669030	DIODE - S3L20U	
D9A80	264P828010	D-CHIP - DAN202U/MA142WK	
D9A81	264P828010	D-CHIP - DAN202U/MA142WK	
D9A82	264P828010	D-CHIP - DAN202U/MA142WK	
D9A83	264P828010	D-CHIP - DAN202U/MA142WK	
D9C22	264P825040	DIODE - ERA15-08	
D9C24	264P045080	DIODE - 1S2076A/1S2471OM	
D9C30	262P097010	DIODE - 11EQS06N-TA2B5	
D9C31	262P097010	DIODE - 11EQS06N-TA2B5	
COILS			
L1A30	321C114010	COIL-RF - 2200MH-J	
L1A31	325C461030	COIL-PEAKING - 10MH-K	
L1B30	321C114010	COIL-RF - 2200MH-J	
L1B31	325C461030	COIL-PEAKING - 10MH-K	
L2AGA	409P864010	EMI-F-CHIP - ACB2012M600	
L2AJA	409P864010	EMI-F-CHIP - ACB2012M600	
L2AKA	409P864010	EMI-F-CHIP - ACB2012M600	
L2ANA	409P864010	EMI-F-CHIP - ACB2012M600	
L2APA	409P864010	EMI-F-CHIP - ACB2012M600	
L2ARA	409P864010	EMI-F-CHIP - ACB2012M600	
L2ATA	409P864010	EMI-F-CHIP - ACB2012M600	
L2AYA	409P864010	EMI-F-CHIP - ACB2012M600	
L2AZA	409P864010	EMI-F-CHIP - ACB2012M600	
L2K05	409P777080	EMI-F-CHIP - BLM21P221S	
L2K42	325C461030	COIL-PEAKING - 10MH-K	
L2K46	325C462080	COIL-PEAKING - 180MH-J	
L2K55	325C462080	COIL-PEAKING - 180MH-J	
L2L28	325C461030	COIL-PEAKING - 10MH-K	
L2M22	325C461050	COIL-PEAKING - 15MH-K	
L2M31	409P777080	EMI-F-CHIP - BLM21P221S	
L2M32	325C461050	COIL-PEAKING - 15MH-K	
L2M38	409P777080	EMI-F-CHIP - BLM21P221S	
L2M45	409P777080	EMI-F-CHIP - BLM21P221S	
L2M46	409P777080	EMI-F-CHIP - BLM21P221S	
L2M50	325C461000	COIL-PEAKING - 5.6MH-K	
L2M53	325C461030	COIL-PEAKING - 10MH-K	
L2M81	409P777080	EMI-F-CHIP - BLM21P221S	
L2MA0	325C461050	COIL-PEAKING - 15MH-K	
L2MA1	325C461030	COIL-PEAKING - 10MH-K	
L2MD1	325C461030	COIL-PEAKING - 10MH-K	
L2N01	325C461030	COIL-PEAKING - 10MH-K	
L2N25	325C462020	COIL-PEAKING - 56MH-K	
L2NA1	325C461030	COIL-PEAKING - 10MH-K	
L2NA2	325C461080	COIL-PEAKING - 27MH-K	
L2NA3	325C461030	COIL-PEAKING - 10MH-K	
L2NC0	325C461030	COIL-PEAKING - 10MH-K	
L2NC1	325C461080	COIL-PEAKING - 27MH-K	
L2P01	325C461030	COIL-PEAKING - 10MH-K	
L2P22	325C461050	COIL-PEAKING - 15MH-K	
L2P25	325C462020	COIL-PEAKING - 56MH-K	
L2P31	325C462020	COIL-PEAKING - 56MH-K	

Ref #	Part #	Part Name & Description	[#]
L2P32	325C461050	COIL-PEAKING - 15MH-K	
L2P41	325C462020	COIL-PEAKING - 56MH-K	
L2R28	325C461030	COIL-PEAKING - 10MH-K	
L3A10	409P923060	EMI-F-CHIP - BLM21B272S	
L3A49	409P923060	EMI-F-CHIP - BLM21B272S	
L3E25	325C502010	COIL-CHIP - SLF12575T-330M3R2-H	
L3E26	325C502010	COIL-CHIP - SLF12575T-330M3R2-H	
L3E51	411D009020	CORE-FERRITE - ZBF503D-01	
L3E52	411D009020	CORE-FERRITE - ZBF503D-01	
L3J01	325C461030	COIL-PEAKING - 10MH-K	
L3J20	325C461030	COIL-PEAKING - 10MH-K	
L3J40	409P777020	EMI-F-CHIP - BLM21A05	
L7A16	409P777050	EMI-F-CHIP - BLM21B201S	
L7A19	409P777050	EMI-F-CHIP - BLM21B201S	
L7A39	409P865060	EMI-F-CHIP - BLM11B141S	
L7A42	409P865060	EMI-F-CHIP - BLM11B141S	
L7A43	409P865060	EMI-F-CHIP - BLM11B141S	
L7A47	409P865060	EMI-F-CHIP - BLM11B141S	
L7A49	409P865060	EMI-F-CHIP - BLM11B141S	
L7A50	409P865060	EMI-F-CHIP - BLM11B141S	
L7A51	409P865060	EMI-F-CHIP - BLM11B141S	
L7A52	409P865060	EMI-F-CHIP - BLM11B141S	
L7A53	409P865060	EMI-F-CHIP - BLM11B141S	
L7A54	409P865060	EMI-F-CHIP - BLM11B141S	
L7A55	409P865060	EMI-F-CHIP - BLM11B141S	
L7A56	409P865060	EMI-F-CHIP - BLM11B141S	
L7A57	409P865060	EMI-F-CHIP - BLM11B141S	
L7A58	409P865060	EMI-F-CHIP - BLM11B141S	
L7A59	409P865060	EMI-F-CHIP - BLM11B141S	
L7A61	409P865060	EMI-F-CHIP - BLM11B141S	
L7A62	409P865060	EMI-F-CHIP - BLM11B141S	
L7A63	409P865060	EMI-F-CHIP - BLM11B141S	
L7A64	409P865060	EMI-F-CHIP - BLM11B141S	
L7A65	409P865060	EMI-F-CHIP - BLM11B141S	
L7A66	409P865060	EMI-F-CHIP - BLM11B141S	
L7A88	409P777050	EMI-F-CHIP - BLM21B201S	
L7A91	409P865060	EMI-F-CHIP - BLM11B141S	
L7A99	409P777050	EMI-F-CHIP - BLM21B201S	
L7ACC	409P777080	EMI-F-CHIP - BLM21P221S	
L7D30	325C241030	COIL-CHIP - 10MH-K	
L7D31	325C241030	COIL-CHIP - 10MH-K	
L7D41	325C241030	COIL-CHIP - 10MH-K	
L7D42	409P777080	EMI-F-CHIP - BLM21P221S	
L7D90	409P777080	EMI-F-CHIP - BLM21P221S	
L7E00	409P777080	EMI-F-CHIP - BLM21P221S	
L7E11	409P777080	EMI-F-CHIP - BLM21P221S	
L7E12	409P777080	EMI-F-CHIP - BLM21P221S	
L7E13	409P777080	EMI-F-CHIP - BLM21P221S	
L7E14	409P777080	EMI-F-CHIP - BLM21P221S	
L7E15	409P777080	EMI-F-CHIP - BLM21P221S	
L7H01	409P777080	EMI-F-CHIP - BLM21P221S	
L7H04	409P777080	EMI-F-CHIP - BLM21P221S	
L7H29	409P777080	EMI-F-CHIP - BLM21P221S	
L7H49	409P777080	EMI-F-CHIP - BLM21P221S	
L7H73	409P777080	EMI-F-CHIP - BLM21P221S	
L7H76	409P777080	EMI-F-CHIP - BLM21P221S	
L7J13	409P777080	EMI-F-CHIP - BLM21P221S	
L7J23	409P777080	EMI-F-CHIP - BLM21P221S	
L7J38	409P777080	EMI-F-CHIP - BLM21P221S	
L7J44	409P777080	EMI-F-CHIP - BLM21P221S	

MODEL: WD-52327 / WD-62327

Model Legend: [a] WD-52327, [b] WD-62327S

Ref #	Part #	Part Name & Description	[#]
L7K01	409P777080	EMI-F-CHIP - BLM21P221S	
L7M90	409P777080	EMI-F-CHIP - BLM21P221S	
L7N01	409P777080	EMI-F-CHIP - BLM21P221S	
L7N02	409P777080	EMI-F-CHIP - BLM21P221S	
L7N11	409P777080	EMI-F-CHIP - BLM21P221S	
L7N21	409P777080	EMI-F-CHIP - BLM21P221S	
L7N31	409P777080	EMI-F-CHIP - BLM21P221S	
L7N41	409P777080	EMI-F-CHIP - BLM21P221S	
L7N61	409P777080	EMI-F-CHIP - BLM21P221S	
L7RF1	409P777050	EMI-F-CHIP - BLM21B201S	
L8C02	409P964010	EMI-F-CHIP - BK2125HS102	
L8C04	409P964010	EMI-F-CHIP - BK2125HS102	
L8C09	409P938020	EMI-F-CHIP - BK1608 LL121	
L8C10	409P938020	EMI-F-CHIP - BK1608 LL121	
L8C11	409P938020	EMI-F-CHIP - BK1608 LL121	
L8C13	409P938020	EMI-F-CHIP - BK1608 LL121	
L8D01	409P777080	EMI-F-CHIP - BLM21P221S	
L8D02	409P777080	EMI-F-CHIP - BLM21P221S	
L8D03	409P777080	EMI-F-CHIP - BLM21P221S	
L8D04	409P964010	EMI-F-CHIP - BK2125HS102	
L8E00	409P777080	EMI-F-CHIP - BLM21P221S	
L8E01	409P777080	EMI-F-CHIP - BLM21P221S	
L8E03	409P777080	EMI-F-CHIP - BLM21P221S	
L8E04	409P777080	EMI-F-CHIP - BLM21P221S	
L8E05	409P777080	EMI-F-CHIP - BLM21P221S	
L8E06	409P777080	EMI-F-CHIP - BLM21P221S	
L8E07	409P777080	EMI-F-CHIP - BLM21P221S	
L8E08	409P777080	EMI-F-CHIP - BLM21P221S	
L8E10	409P777080	EMI-F-CHIP - BLM21P221S	
L8E11	409P777080	EMI-F-CHIP - BLM21P221S	
L8E12	409P777080	EMI-F-CHIP - BLM21P221S	
L8E13	409P777080	EMI-F-CHIP - BLM21P221S	
L8H01	409P777080	EMI-F-CHIP - BLM21P221S	
L9A01	411P011010	FERITE-BEADS - ZBF-503S-P	
L9A02	411P011010	FERITE-BEADS - ZBF-503S-P	
L9A10	321C151070	COIL-RF - 22MH-K	
L9A19	321C141010	COIL-RF - 6.8MH-M	
L9A20	321C141010	COIL-RF - 6.8MH-M	
L9A21	321C141010	COIL-RF - 6.8MH-M	
L9A22	321C141030	COIL-RF - 10MH-K	
L9A23	321C141030	COIL-RF - 10MH-K	
L9A30	321C140060	COIL-RF - 2.7MH-M	
L9A31	321C140060	COIL-RF - 2.7MH-M	
L9A32	321C140060	COIL-RF - 2.7MH-M	
L9A33	351P250010	COIL-CHOKE - GSTC6018-100M	
L9A62	321C141010	COIL-RF - 6.8MH-M	
L9A63	321C141090	COIL-RF - 33MH-K	
L9A64	321C141090	COIL-RF - 33MH-K	
L9A70	321C141090	COIL-RF - 33MH-K	
L9A71	321C141090	COIL-RF - 33MH-K	
L9AAA	325C462020	COIL-PEAKING - 56MH-K	
L9B70	321C141090	COIL-RF - 33MH-K	
L9C20	321C141070	COIL-RF - 22MH-K	
L9C21	321C141070	COIL-RF - 22MH-K	
L9D00	351P268010	LINE-FILTER - HF3545-502Y5R0-TXXBH	
L9D01	351P268010	LINE-FILTER - HF3545-502Y5R0-TXXBH	
L9D02	351P268010	LINE-FILTER - HF3545-502Y5R0-TXXBH	
LC1A10	409P875090	EMI-F-CHIP - ELKE103FA	
LC1A11	409P876020	EMI-F-CHIP - CNF20C470S/CKD510JB1H470S	
LC1A12	409P876020	EMI-F-CHIP - CNF20C470S/CKD510JB1H470S	

Ref #	Part #	Part Name & Description	[#]
LC1A13	409P876020	EMI-F-CHIP - CNF20C470S/CKD510JB1H470S	
LC1A14	409P876020	EMI-F-CHIP - CNF20C470S/CKD510JB1H470S	
LC1A15	409P876020	EMI-F-CHIP - CNF20C470S/CKD510JB1H470S	
LC1A16	409P876020	EMI-F-CHIP - CNF20C470S/CKD510JB1H470S	
LC1A17	409P876020	EMI-F-CHIP - CNF20C470S/CKD510JB1H470S	
LC1A18	409P876020	EMI-F-CHIP - CNF20C470S/CKD510JB1H470S	
LC1A19	409P876020	EMI-F-CHIP - CNF20C470S/CKD510JB1H470S	
LC1A20	409P876020	EMI-F-CHIP - CNF20C470S/CKD510JB1H470S	
LC2A21	409P875090	EMI-F-CHIP - ELKE103FA	
LC2A24	409P876020	EMI-F-CHIP - CNF20C470S/CKD510JB1H470S	
LC2A25	409P876020	EMI-F-CHIP - CNF20C470S/CKD510JB1H470S	
LC2A26	409P876020	EMI-F-CHIP - CNF20C470S/CKD510JB1H470S	
LC2A27	409P876020	EMI-F-CHIP - CNF20C470S/CKD510JB1H470S	
LC2A28	409P876020	EMI-F-CHIP - CNF20C470S/CKD510JB1H470S	
LC2A31	409P875090	EMI-F-CHIP - ELKE103FA	
LC2J40	409P777020	EMI-F-CHIP - BLM21A05	
LC2J41	409P777020	EMI-F-CHIP - BLM21A05	
LC2J42	409P777020	EMI-F-CHIP - BLM21A05	
LC2J43	409P777020	EMI-F-CHIP - BLM21A05	
LC3A10	409P876020	EMI-F-CHIP - CNF20C470S/CKD510JB1H470S	
LC3A11	409P876020	EMI-F-CHIP - CNF20C470S/CKD510JB1H470S	
LC3A12	409P875090	EMI-F-CHIP - ELKE103FA	
LC3A13	409P876020	EMI-F-CHIP - CNF20C470S/CKD510JB1H470S	
LC3A14	409P876020	EMI-F-CHIP - CNF20C470S/CKD510JB1H470S	
LC3A15	409P875090	EMI-F-CHIP - ELKE103FA	
LC3A16	409P875090	EMI-F-CHIP - ELKE103FA	
LC3A20	409P876020	EMI-F-CHIP - CNF20C470S/CKD510JB1H470S	
LC3J41	409P777020	EMI-F-CHIP - BLM21A05	
LC7A00	409P865060	EMI-F-CHIP - BLM11B141S	
LC7A01	409P865060	EMI-F-CHIP - BLM11B141S	
LC7A02	409P876020	EMI-F-CHIP - CNF20C470S/CKD510JB1H470S	
LC7A03	409P876020	EMI-F-CHIP - CNF20C470S/CKD510JB1H470S	
LC7A04	409P876020	EMI-F-CHIP - CNF20C470S/CKD510JB1H470S	
LC7A05	409P876020	EMI-F-CHIP - CNF20C470S/CKD510JB1H470S	
LC7A06	409P876020	EMI-F-CHIP - CNF20C470S/CKD510JB1H470S	
LC7A07	409P876020	EMI-F-CHIP - CNF20C470S/CKD510JB1H470S	
LC7A08	409P876020	EMI-F-CHIP - CNF20C470S/CKD510JB1H470S	
LC7A19	409P876020	EMI-F-CHIP - CNF20C470S/CKD510JB1H470S	
LC7A20	409P876020	EMI-F-CHIP - CNF20C470S/CKD510JB1H470S	
LC7A21	409P876020	EMI-F-CHIP - CNF20C470S/CKD510JB1H470S	
LC7A22	409P876020	EMI-F-CHIP - CNF20C470S/CKD510JB1H470S	
LC7A23	409P876020	EMI-F-CHIP - CNF20C470S/CKD510JB1H470S	
LC7A24	409P876020	EMI-F-CHIP - CNF20C470S/CKD510JB1H470S	
LC7A26	409P876020	EMI-F-CHIP - CNF20C470S/CKD510JB1H470S	
LC7A27	409P876020	EMI-F-CHIP - CNF20C470S/CKD510JB1H470S	
LC7D02	409P777080	EMI-F-CHIP - BLM21P221S	
LC7D10	409P876020	EMI-F-CHIP - CNF20C470S/CKD510JB1H470S	
LC7D11	409P876020	EMI-F-CHIP - CNF20C470S/CKD510JB1H470S	
LC7D12	409P876020	EMI-F-CHIP - CNF20C470S/CKD510JB1H470S	
LC7D13	409P876020	EMI-F-CHIP - CNF20C470S/CKD510JB1H470S	
LC7D14	409P876020	EMI-F-CHIP - CNF20C470S/CKD510JB1H470S	
LC7E10	409P876020	EMI-F-CHIP - CNF20C470S/CKD510JB1H470S	
LC7E11	409P876020	EMI-F-CHIP - CNF20C470S/CKD510JB1H470S	
LC7E12	409P876020	EMI-F-CHIP - CNF20C470S/CKD510JB1H470S	
LC7E13	409P876020	EMI-F-CHIP - CNF20C470S/CKD510JB1H470S	
LC7E14	409P876020	EMI-F-CHIP - CNF20C470S/CKD510JB1H470S	
LC8E02	409P876020	EMI-F-CHIP - CNF20C470S/CKD510JB1H470S	
LC8E03	409P876020	EMI-F-CHIP - CNF20C470S/CKD510JB1H470S	
LC8E05	409P876020	EMI-F-CHIP - CNF20C470S/CKD510JB1H470S	
LC8E06	409P876020	EMI-F-CHIP - CNF20C470S/CKD510JB1H470S	

[#] Model Legend: [a] WD-52327, [b] WD-62327

Ref #	Part #	Part Name & Description	[#]
LC8E07	409P876020	EMI-F-CHIP - CNF20C470S/CKD510JB1H470S	
LC8E08	409P876020	EMI-F-CHIP - CNF20C470S/CKD510JB1H470S	
LC8E09	409P876020	EMI-F-CHIP - CNF20C470S/CKD510JB1H470S	
LC8E22	409P876020	EMI-F-CHIP - CNF20C470S/CKD510JB1H470S	
LC8E23	409P876020	EMI-F-CHIP - CNF20C470S/CKD510JB1H470S	
LC8E24	409P876020	EMI-F-CHIP - CNF20C470S/CKD510JB1H470S	
LC8E25	409P876020	EMI-F-CHIP - CNF20C470S/CKD510JB1H470S	
LC8E26	409P876020	EMI-F-CHIP - CNF20C470S/CKD510JB1H470S	
LC8E27	409P876020	EMI-F-CHIP - CNF20C470S/CKD510JB1H470S	
LC8E28	409P876020	EMI-F-CHIP - CNF20C470S/CKD510JB1H470S	
LC8E29	409P875090	EMI-F-CHIP - ELKE103FA	
LC8E30	409P875090	EMI-F-CHIP - ELKE103FA	
LC8E31	409P876020	EMI-F-CHIP - CNF20C470S/CKD510JB1H470S	
LC8E32	409P876020	EMI-F-CHIP - CNF20C470S/CKD510JB1H470S	
LC9A10	409P875090	EMI-F-CHIP - ELKE103FA	
LC9A11	409P875090	EMI-F-CHIP - ELKE103FA	
LC9A12	409P875090	EMI-F-CHIP - ELKE103FA	
LC9A13	409P875090	EMI-F-CHIP - ELKE103FA	
LC9A14	409P875090	EMI-F-CHIP - ELKE103FA	
LC9A15	409P875090	EMI-F-CHIP - ELKE103FA	
LC9A16	409P875090	EMI-F-CHIP - ELKE103FA	
LC9A17	409P875090	EMI-F-CHIP - ELKE103FA	

TRANSFORMERS

T9A10	350P830010	TRANS-PWR - SRW39LEC-U10V117
T9C20	350P806010	TRANS-PWR - ETS19AB1R5BG

VARIABLE RESISTORS

RV9D00	265P100020	VAR - ERZV10D271CS
RV9D01	265P100020	VAR - ERZV10D271CS

RESISTORS

CHIP Type Resistors (Listed by Value)

Part No.	Value	Part No.	Value
103P509050	1/16W 0OHM	103P492060	1/16W 1.1K-F
103P508040	1/16W 2.2-J	103P502060	1/16W 1.2K-J
103P509000	1/16W 6.8-J	103P492080	1/16W 1.3K-F
103P400050	1/10W 22-J	103P492090	1/16W 1.5K-F
103P910050	1/16W 22-J	103P502070	1/16W 1.5K-J
103P500050	1/16W 22-J	103P472090	1/8W 1.5K-F
103P500070	1/16W 33-J	103P493000	1/16W 1.6K-F
103P500080	1/16W 39-J	103P502080	1/16W 1.8K-J
103P910090	1/16W 47-J	103P493020	1/16W 2K-F
103P400090	1/10W 47-J	103P493030	1/16W 2.2K-F
103P500090	1/16W 47-J	103P502090	1/16W 2.2K-J
103P501000	1/16W 56-J	103P493050	1/16W 2.7K-F
103P501010	1/16W 68-J	103P503000	1/16W 2.7K-J
103P794060	1/16W 75-F	103P493060	1/16W 3K-F
103P509090	1/16W 75-J	103P493070	1/16W 3.3K-F
103P501020	1/16W 82-J	103P503010	1/16W 3.3K-J
103P401030	1/10W 100-J	103P493090	1/16W 3.9K-F
103P501030	1/16W 100-J	103P503020	1/16W 3.9K-J
103P501040	1/16W 120-J	103P503030	1/16W 4.7K-J
103P401050	1/10W 150-J	103P494030	1/16W 5.6K-F
103P490050	1/16W 150-F	103P503040	1/16W 5.6K-J
103P501050	1/16W 150-J	103P503050	1/16W 6.8K-J
103P501060	1/16W 180-J	103P503060	1/16W 8.2K-J
103P501070	1/16W 220-J	103P494080	1/16W 9.1K-F
103P470090	1/8W 220-F	103P494090	1/16W 10K-F

Ref #	Part #	Part Name & Description	[#]
	103P491000	1/16W 240-F	103P503070 1/16W 10K-J
	103P501080	1/16W 270-J	103P495010 1/16W 12K-F
	103P401080	1/10W 270-J	103P503080 1/16W 12K-J
	103P491020	1/16W 300-F	103P503090 1/16W 15K-J
	103P501090	1/16W 330-J	103P504000 1/16W 18K-J
	103P491040	1/16W 360-F	103P504010 1/16W 22K-J
	103P491050	1/16W 390-F	103P496000 1/16W 30K-F
	103P502000	1/16W 390-J	103P496010 1/16W 33K-F
	103P491060	1/16W 430-F	103P504030 1/16W 33K-J
	103P491070	1/16W 470-F	103P504040 1/16W 39K-J
	103P502010	1/16W 470-J	103P504050 1/16W 47K-J
	103P491090	1/16W 560-F	103P504060 1/16W 56K-J
	103P502020	1/16W 560-J	103P504070 1/16W 68K-J
	103P492000	1/16W 620-F	103P504080 1/16W 82K-J
	103P492010	1/16W 680-F	103P504090 1/16W 100K-J
	103P502030	1/16W 680-J	103P505000 1/16W 120K-J
	103P505090	1/16W 680K-J	103P505010 1/16W 150K-J
	103P492030	1/16W 820-F	103P505050 1/16W 330K-J
	103P502040	1/16W 820-J	103P506000 1/16W 820K-J
	103P492050	1/16W 1K-F	103P506010 1/16W 1M-J
	103P502050	1/16W 1K-J	

RESISTORS

Conventional Resistors (By Ref #)

Ref #	Part #	Part Name & Description	[#]
R2J21	109D151050	R-CARBON - 1/4W 75-J	
R2J31	109D151050	R-CARBON - 1/4W 75-J	
R3E27	109D151030	R-CARBON - 1/4W 4.7-J	
R3E28	103C170050	R-METAL - 1W 22-J	
R3E29	109D151030	R-CARBON - 1/4W 4.7-J	
R3E30	109D151030	R-CARBON - 1/4W 4.7-J	
R3E31	109D151030	R-CARBON - 1/4W 4.7-J	
R3E32	103C170050	R-METAL - 1W 22-J	
R9A01	109P179010	R-CEMENT-PLATE - 6.8-J	
R9A02	109P179010	R-CEMENT-PLATE - 6.8-J	
R9A03	109C010010	R-COMP - 1/2W 1M-K	
R9A05	109C010010	R-COMP - 1/2W 1M-K	
R9A06	109C010010	R-COMP - 1/2W 1M-K	
R9A09	103P145030	R-CARBON - 1/2W 220K-J	
R9A11	103P145030	R-CARBON - 1/2W 220K-J	
R9A13	103C194090	R-METAL - 3W 100K-J	
R9A14	103C194090	R-METAL - 3W 100K-J	
R9A15	103C394020	R-METAL-P - 3W 27K	
R9A16	103P145020	R-CARBON - 1/2W 180K-J	
R9A17	103P145020	R-CARBON - 1/2W 180K-J	
R9A18	103P145020	R-CARBON - 1/2W 180K-J	
R9A19	103P144020	R-CARBON - 1/2W 27K-J	
R9A20	103P144020	R-CARBON - 1/2W 27K-J	
R9A21	103C177040	R-METAL - 1W 0.33-J	
R9A22	103C177040	R-METAL - 1W 0.33-J	
R9A25	103P142050	R-CARBON - 1/2W 1K-J	
R9A26	109D151060	R-CARBON - 1/4W 68-J	
R9A27	109D151050	R-CARBON - 1/4W 75-J	
R9A66	103P712000	R-CARBON - 1/4W 390-J	
R9A67	103P712000	R-CARBON - 1/4W 390-J	
R9A68	103P712000	R-CARBON - 1/4W 390-J	
R9A69	103P712000	R-CARBON - 1/4W 390-J	
R9A76	103C392010	R-METAL-P - 3W 470-J	
R9A77	103C392010	R-METAL-P - 3W 470-J	

Model Legend: [a] WD-52327, [b] WD-623275

Ref #	Part #	Part Name & Description	[#]
R9A89	103P141090	R-CARBON 1/2W 330-J	
R9A90	103C394020	R-METAL-P - 3W 27K	
R9A91	103C394020	R-METAL-P - 3W 27K	
R9A92	103C288040	R-METAL-CP - 2W 2.2-J	
R9C20	103C391020	R-METAL-P - 3W 82-J	
R9C21	103P712050	R-CARBON - 1/4W 1K-J	
R9C23	103P710090	R-CARBON - 1/4W 47-J	
R9C24	103P142070	R-CARBON - 1/2W 1.5K-J	
R9C25	103P462050	R-METAL - 1/4W 1K-F	
R9C26	103P462050	R-METAL - 1/4W 1K-F	
R9C27	103P712050	R-CARBON - 1/4W 1K-J	
R9C28	103P713070	R-CARBON - 1/4W 10K-J	
R9C29	103P711030	R-CARBON - 1/4W 100-J	
R9C30	103P710080	R-CARBON - 1/4W 39-J	
R9D00	109D036020	R-COMP - 1/2W 4.7M-K	

CAPACITORS

CHIP Type Capacitors (Listed by Value)

Part No.	Value	Part No.	Value
154P340040	50V 3P-C	141P143080	F50V 0.01M-Z
154P341010	CH50V 10P-C	141P133080	F50V 0.01M-Z
154P351020	SL50V 10P-J	141P132030	B50V 0.015M-K
154P341030	CH50V 12P-J	141P142090	B25V 0.047M-K
154P341050	CH50V 15P-J	141P143020	B16V 0.082M-K
154P341090	CH50V 22P-J	141P143030	B16V 0.1M-K
154P342010	CH50V 27P-J	141P144020	F25V 0.1M-Z
154P342030	CH50V 33P-J	141P134090	F50V 0.1M-Z
154P342070	CH50V 47P-J	141P139030	B25V 0.1M-K
154P342090	CH50V 56P-J	141P146040	B10V 0.22M-K
154P353000	SL50V 56P-J	141P138080	B25V 0.33M-K
154P343050	CH50V 100P-J	141P146080	B10V 0.47M-K
141P140010	B50V 220P-K	141P139090	B16V 0.47M-K
154P344050	CH50V 270P-J	181P526010	50V 1M-M
154P344070	CH50V 330P-J	141P147020	B10V/6.3V 1M-K
141P140050	B50V 470P-K	141P134070	B16V 1M-K
141P140060	B50V 560P-K	181P526020	50V 2.2M-M
154P345030	CH25V 560P-J	181P532030	16V 10M-M
154P345050	CH25V 680P-J	181P508080	16V 10M-M
154P345070	CH25V 820P-J	181P522030	16V 10M-M 105C
154P345010	CH50V 470P-J	181P530030	6.3V 47M-M
141P140090	B50V 1000P-K	181P520030	6.3V 47M-M
154P345090	CH25V 1000P-J	181P522060	6V 47M-M
141P141010	B50V 1500P-K	181P502070	16V 100M-M
141P141030	B50V 2200P-K	181P520040	6.3V 100M-M
		181P500060	6.3V 220M-M

CAPACITORS AND TRIMMERS

Conventional Capacitors (By Ref #)

Ref #	Part #	Part Name & Description	[#]
C1A13	181P352040	C-ELEC - 16V 100M-M	
C1A21	181P352040	C-ELEC - 16V 100M-M	
C1A24	181P352040	C-ELEC - 16V 100M-M	
C1A26	172P262010	C-M-POLY - 50V 0.047M-J	
C1B13	181P355090	C-ELEC - 50V 100M-M	
C1B21	181P352040	C-ELEC - 16V 100M-M	
C1B24	181P352040	C-ELEC - 16V 100M-M	
C1B26	172P262010	C-M-POLY - 50V 0.047M-J	
C2AGC	155P239040	C-CER - CH50V 100P-J	
C2AGD	142P024060	C-CER - BF50V 0.1M-Z	

Ref #	Part #	Part Name & Description	[#]
C2AJB	142P024060	C-CER - BF50V 0.1M-Z	
C2AJD	155P239040	C-CER - CH50V 100P-J	
C2AKC	181P352040	C-ELEC - 16V 100M-M	
C2AKD	155P239040	C-CER - CH50V 100P-J	
C2ANC	142P024060	C-CER - BF50V 0.1M-Z	
C2AND	155P239040	C-CER - CH50V 100P-J	
C2APC	181P352040	C-ELEC - 16V 100M-M	
C2APD	155P239040	C-CER - CH50V 100P-J	
C2ARC	142P024060	C-CER - BF50V 0.1M-Z	
C2ARD	155P239040	C-CER - CH50V 100P-J	
C2ATC	142P024060	C-CER - BF50V 0.1M-Z	
C2ATD	155P239040	C-CER - CH50V 100P-J	
C2AYC	142P024060	C-CER - BF50V 0.1M-Z	
C2AYD	155P239040	C-CER - CH50V 100P-J	
C2AZC	142P024060	C-CER - BF50V 0.1M-Z	
C2AZE	181P355050	C-ELEC - 50V 10M-M	
C2AZF	155P239040	C-CER - CH50V 100P-J	
C2K01	181P355050	C-ELEC - 50V 10M-M	
C2K03	181P355050	C-ELEC - 50V 10M-M	
C2K08	181P355050	C-ELEC - 50V 10M-M	
C2K10	181P355050	C-ELEC - 50V 10M-M	
C2K15	181P355050	C-ELEC - 50V 10M-M	
C2K17	181P355050	C-ELEC - 50V 10M-M	
C2K18	181P351060	C-ELEC - 10V 330M-M	
C2K22	181P355050	C-ELEC - 50V 10M-M	
C2K27	181P355050	C-ELEC - 50V 10M-M	
C2K43	181P352030	C-ELEC - 16V 47M-M	
C2K48	181P352030	C-ELEC - 16V 47M-M	
C2K50	181P355050	C-ELEC - 50V 10M-M	
C2K63	181P355050	C-ELEC - 50V 10M-M	
C2K71	181P352030	C-ELEC - 16V 47M-M	
C2K75	181P352030	C-ELEC - 16V 47M-M	
C2L29	181P352030	C-ELEC - 16V 47M-M	
C2L52	181P352030	C-ELEC - 16V 47M-M	
C2M28	181P351080	C-ELEC - 10V 1000M-M	
C2M29	181P351080	C-ELEC - 10V 1000M-M	
C2M31	181P352030	C-ELEC - 16V 47M-M	
C2M34	181P352030	C-ELEC - 16V 47M-M	
C2M36	181P352030	C-ELEC - 16V 47M-M	
C2M38	181P352030	C-ELEC - 16V 47M-M	
C2M43	181P352030	C-ELEC - 16V 47M-M	
C2M44	181P352030	C-ELEC - 16V 47M-M	
C2M54	181P355050	C-ELEC - 50V 10M-M	
C2M64	181P352030	C-ELEC - 16V 47M-M	
C2M80	181P352030	C-ELEC - 16V 47M-M	
C2M88	181P355010	C-ELEC - 50V 1M-M	
C2M89	181P352030	C-ELEC - 16V 47M-M	
C2M98	181P355050	C-ELEC - 50V 10M-M	
C2MA4	181P352030	C-ELEC - 16V 47M-M	
C2MA6	181P352030	C-ELEC - 16V 47M-M	
C2MA9	181P352030	C-ELEC - 16V 47M-M	
C2MC4	181P352030	C-ELEC - 16V 47M-M	
C2MC8	181P352040	C-ELEC - 16V 100M-M	
C2MD6	181P352040	C-ELEC - 16V 100M-M	
C2MD7	181P352040	C-ELEC - 16V 100M-M	
C2N03	181P352070	C-ELEC - 16V 470M-M	
C2N27	181P350060	C-ELEC - 3V 1000M-M	
C2NA6	181P355050	C-ELEC - 50V 10M-M	
C2NC5	181P355050	C-ELEC - 50V 10M-M	
C2P01	181P352070	C-ELEC - 16V 470M-M	

MODEL: WD-52327 / WD-62327

[#] Model Legend: [a] WD-52327, [b] WD-62327

Ref #	Part #	Part Name & Description	[#]
C2P26	181P350060	C-ELEC - 3V 1000M-M	
C2P32	181P352030	C-ELEC - 16V 47M-M	
C2P42	181P352030	C-ELEC - 16V 47M-M	
C2R29	181P352030	C-ELEC - 16V 47M-M	
C3A14	181P355050	C-ELEC - 50V 10M-M	
C3A20	181P355050	C-ELEC - 50V 10M-M	
C3A21	181P355050	C-ELEC - 50V 10M-M	
C3A28	181P355050	C-ELEC - 50V 10M-M	
C3A29	181P355050	C-ELEC - 50V 10M-M	
C3A32	181P355050	C-ELEC - 50V 10M-M	
C3A33	181P355050	C-ELEC - 50V 10M-M	
C3A34	181P355030	C-ELEC - 50V 3.3M-M	
C3A46	181P355050	C-ELEC - 50V 10M-M	
C3A49	181P355050	C-ELEC - 50V 10M-M	
C3E50	181P358070	C-ELEC - 63V 22M-M	
C3E51	181P354090	C-ELEC - 35V 470M-M	
C3E52	181P354090	C-ELEC - 35V 470M-M	
C3E53	181P354090	C-ELEC - 35V 470M-M	
C3E54	181P354090	C-ELEC - 35V 470M-M	
C3F91	181P375050	C-ELE-BP-AUDIO - 25V 1000M-M	
C3F92	181P375050	C-ELE-BP-AUDIO - 25V 1000M-M	
C3J01	181P352030	C-ELEC - 16V 47M-M	
C3J05	181P355050	C-ELEC - 50V 10M-M	
C3J06	181P122070	C-ELEC-NP - 25V 10M-M	
C3J09	181P355050	C-ELEC - 50V 10M-M	
C3J10	181P122070	C-ELEC-NP - 25V 10M-M	
C3J24	181P352030	C-ELEC - 16V 47M-M	
C3K02	181P355010	C-ELEC - 50V 1M-M	
C3K04	181P355010	C-ELEC - 50V 1M-M	
C3K09	181P355010	C-ELEC - 50V 1M-M	
C3K11	181P355010	C-ELEC - 50V 1M-M	
C3K16	181P355010	C-ELEC - 50V 1M-M	
C3K18	181P355010	C-ELEC - 50V 1M-M	
C3K23	181P355010	C-ELEC - 50V 1M-M	
C3K25	181P355010	C-ELEC - 50V 1M-M	
C3K29	181P355010	C-ELEC - 50V 1M-M	
C3K31	181P355010	C-ELEC - 50V 1M-M	
C3K62	181P355010	C-ELEC - 50V 1M-M	
C3K64	181P355010	C-ELEC - 50V 1M-M	
C7A00	154P345050	C-CER-CHIP - CH25V 680P-J	
C7A16	181P352030	C-ELEC - 16V 47M-M	
C7A99	181P352030	C-ELEC - 16V 47M-M	
C7ACB	181P355050	C-ELEC - 50V 10M-M	
C7B02	181P355020	C-ELEC - 50V 2.2M-M	
C7B88	181P355050	C-ELEC - 50V 10M-M	
C7B96	181P355020	C-ELEC - 50V 2.2M-M	
C7C56	181P352030	C-ELEC - 16V 47M-M	
C7C57	181P352030	C-ELEC - 16V 47M-M	
C7D00	181P352040	C-ELEC - 16V 100M-M	
C7D97	181P352040	C-ELEC - 16V 100M-M	
C7K01	181P352030	C-ELEC - 16V 47M-M	
C7RF2	181P355050	C-ELEC - 50V 10M-M	
C7S03	181P352030	C-ELEC - 16V 47M-M	
C9A00	189P185090	C-CER - AC250V E2200P-M	
C9A01	189P185090	C-CER - AC250V E2200P-M	
C9A02	185D122050	C-ELEC - H200V 1000M-M	
C9A03	185D122050	C-ELEC - H200V 1000M-M	
C9A04	185D127040	C-ELEC - H450V 150M-M 105C	
C9A05	189P185090	C-CER - AC250V E2200P-M	
C9A06	189P185090	C-CER - AC250V E2200P-M	

Ref #	Part #	Part Name & Description	[#]
C9A08	189P185090	C-CER - AC250V E2200P-M	
C9A09	189P185090	C-CER - AC250V E2200P-M	
C9A10	189P185090	C-CER - AC250V E2200P-M	
C9A11	189P185090	C-CER - AC250V E2200P-M	
C9A12	189P153010	C-M-POLY - AC125/250V 0.33M-M	
C9A13	189P152070	C-M-POLY - 250VAC 0.01M-M	
C9A14	189P152070	C-M-POLY - 250VAC 0.01M-M	
C9A15	189P185070	C-CER - AC250V E1000P-M	
C9A16	189P185070	C-CER - AC250V E1000P-M	
C9A20	154P262070	C-CER - R2KV820P-K	
C9A21	181P185060	C-ELEC - 50V 10M-M 105C	
C9A25	172P138010	C-POLY - 50V 4700P-J	
C9A26	185D122050	C-ELEC - H200V 1000M-M	
C9A27	185D122050	C-ELEC - H200V 1000M-M	
C9A29	181P185060	C-ELEC - 50V 10M-M 105C	
C9A30	181P185060	C-ELEC - 50V 10M-M 105C	
C9A32	181P735040	C-ELEC - 25V 1500M-M	
C9A33	181P735040	C-ELEC - 25V 1500M-M	
C9A35	181P735010	C-ELEC - 25V 470M-M	
C9A37	181P732040	C-ELEC - 10V 3300M-M 105C	
C9A38	181P732040	C-ELEC - 10V 3300M-M 105C	
C9A39	181P184070	C-ELEC - 35V 2200M-M	
C9A40	181P184070	C-ELEC - 35V 2200M-M	
C9A41	181P732010	C-ELEC - 10V 1000M-M 105C	
C9A43	172P262050	C-M-POLY - 50V 0.1M-J	
C9A45	181P182030	C-ELEC - 16V 1000M-M 105C	
C9A46	142P010090	C-CER - B500V 470P-K	
C9A47	142P010090	C-CER - B500V 470P-K	
C9A51	181P182030	C-ELEC - 16V 1000M-M 105C	
C9A52	181P182030	C-ELEC - 16V 1000M-M 105C	
C9A61	181P182030	C-ELEC - 16V 1000M-M 105C	
C9A62	181P182030	C-ELEC - 16V 1000M-M 105C	
C9A64	181P181000	C-ELEC - 10V 330M-M 105C	
C9A71	181P183010	C-ELEC - 25V 100M-M	
C9A73	181P735020	C-ELEC - 25V 1000M-M 105C	
C9A77	181P183010	C-ELEC - 25V 100M-M	
C9A79	181P183010	C-ELEC - 25V 100M-M	
C9A82	181P183010	C-ELEC - 25V 100M-M	
C9AAB	181P351070	C-ELEC - 10V 470M-M	
C9ABA	181P352040	C-ELEC - 16V 100M-M	
C9B71	181P183010	C-ELEC - 25V 100M-M	
C9B73	181P735020	C-ELEC - 25V 1000M-M 105C	
C9C01	181P352030	C-ELEC - 16V 47M-M	
C9C02	181P352030	C-ELEC - 16V 47M-M	
C9C11	181P352030	C-ELEC - 16V 47M-M	
C9C12	181P352030	C-ELEC - 16V 47M-M	
C9C15	181P355010	C-ELEC - 50V 1M-M	
C9C16	189P185070	C-CER - AC250V E1000P-M	
C9C17	189P185070	C-CER - AC250V E1000P-M	
C9C21	181P352030	C-ELEC - 16V 47M-M	
C9C22	181P199080	C-ELEC - 200V 47M-M/Q	
C9C22	181P352040	C-ELEC - 16V 100M-M	
C9C25	172P262050	C-M-POLY - 50V 0.1M-J	
C9C27	154P270050	C-CER - SL1KV 22P-J	
C9C28	172P262050	C-M-POLY - 50V 0.1M-J	
C9C29	142P010090	C-CER - B500V 470P-K	
C9C30	142P010090	C-CER - B500V 470P-K	
C9C31	181P743040	C-ELEC - 16V 330M-M	
C9C32	181P352040	C-ELEC - 16V 100M-M	
C9C33	181P354060	C-ELEC - 35V 100M-M	

[#] Model Legend: [a] WD-52327, [b] WD-62327

Ref #	Part #	Part Name & Description	[#]
PRINTED CIRCUIT BOARDS			
	930B929001	ASSY-PWB-POWER	
	930B930001	ASSY-PWB-SIGNAL	
	930B931001	ASSY-PWB-FMT	
	930B932001	ASSY-PWB-TERMINAL	
	934C148001	ASSY-PWB-POWER-SUB	
	934C149001	ASSY-PWB-AUDIO	
	935D811001	ASSY-PWB-PREAMP	
	935D812001	ASSY-PWB-FRONT	
	935D813001	ASSY-PWB-CONTROL	
	935D814001	ASSY-PWB-SPEAKER-R	
	935D815001	ASSY-PWB-SPEAKER-L	
	955B310001	ASSY-CHASSIS	

Ref #	Part #	Part Name & Description	[#]
COSMETIC PARTS			
	760A016010	INLAY TERMINAL	
	761A233010	GRILLE - SPEAKER	a
	761A239010	GRILLE - SPEAKER	b
	775B142080	NAME-PLATE - WD-52327	a
	775B142090	NAME-PLATE - WD-62327	b
	850C095010	INLAY FRONT	
ACCESSORIES			
	246C351050	CORD-AC - POWER	
	290P116010	REMOTE CONTROL - V22/V24	
	I/QR WD5237	GUIDE - QR - VK26	
	I/B WD52327	GUIDE - OWNERS - VK26	

MODEL: WD-52327 / WD-62327

Model Legend: [a] WD-52327, [b] WD-623275

Ref #	Part #	Part Name & Description	[#]	Ref #	Part #	Part Name & Description	[#]
SCREEN ASSEMBLY PARTS							
WD-52327				WD-62327			
(1)	491P175010	LENS-FRESNEL		(1)	491P175020	LENS-FRESNEL	
(2)	491P176030	SCREEN-LENTICULAR		(2)	491P176040	SCREEN-LENTICULAR	
(3)	623D174010	SCREEN - HOLDER		(3)	623D253010	SCREEN - HOLDER	
(4)	701B499050	SCREEN FRAME - TOP		(4)	701B525010	SCREEN FRAME - TOP	
(5)	701B517050	SCREEN FRAME - SIDE		(5)	701B526030	SCREEN FRAME - SIDE	
(12)	704B206010	SCREEN - TRIM - LEFT		(14)	704B208010	SCREEN - TRIM - LEFT	
(13)	704B206020	SCREEN - TRIM - RIGHT		(15)	704B208020	SCREEN - TRIM - RIGHT	
(6)	761A232030	SCREEN FRAME - BOTTOM		(6)	761A242030	SCREEN FRAME - BOTTOM	
(7)	761A238030	SCREEN COVER - TOP		(7)	761A244030	SCREEN FRAME - TOP COVER	
(8)	768C082010	SCREEN-CAP-CORNER - LEFT		(8)	768C082010	SCREEN-CAP-CORNER - LEFT	
(9)	768C082020	SCREEN-CAP-CORNER - RIGHT		(9)	768C082020	SCREEN-CAP-CORNER - RIGHT	
(10)	761A252010	BEZEL - FRONT		(10)	761A253010	BEZEL - FRONT	
(11)	623D209010	SHEET-BOTTOM		(11)	623D209020	SHEET-BOTTOM	

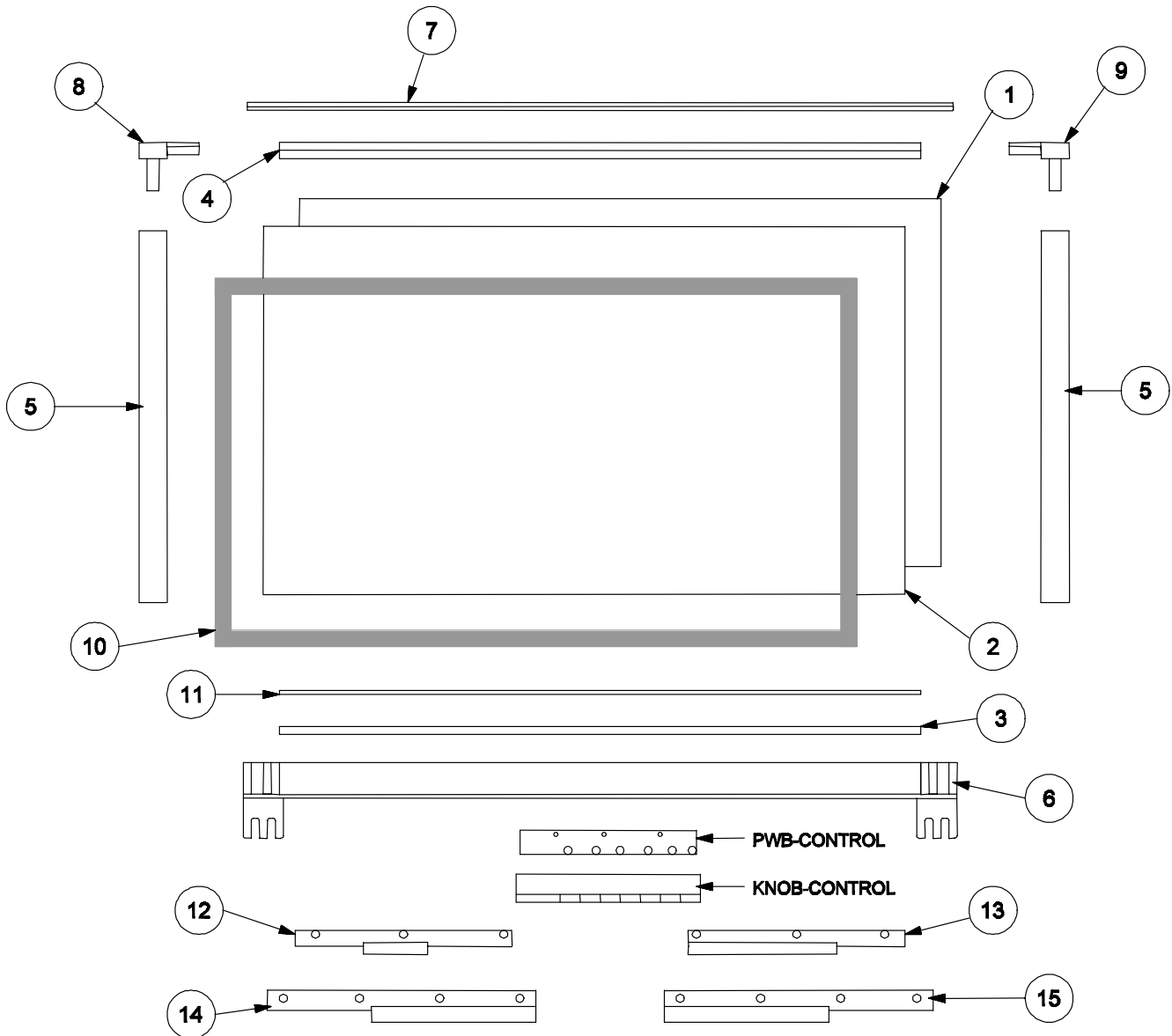

STANDBY SUPPLIES

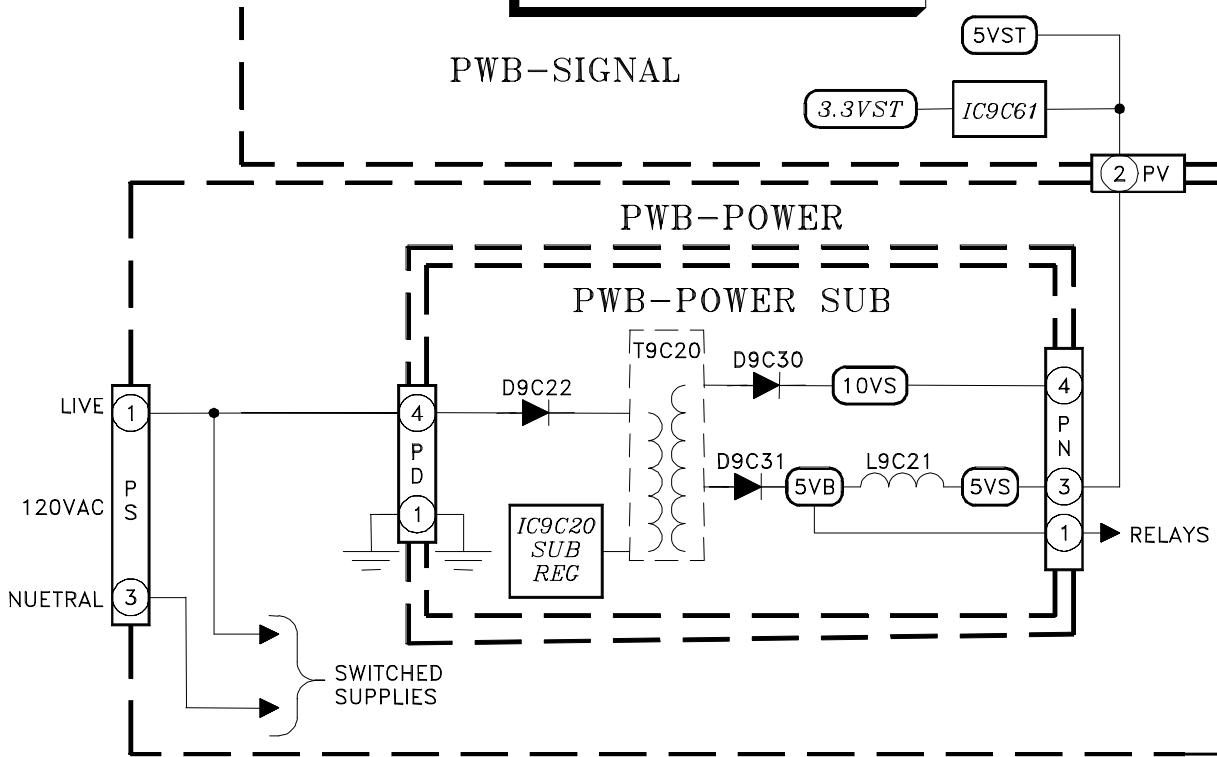

SWITCHED SUPPLIES

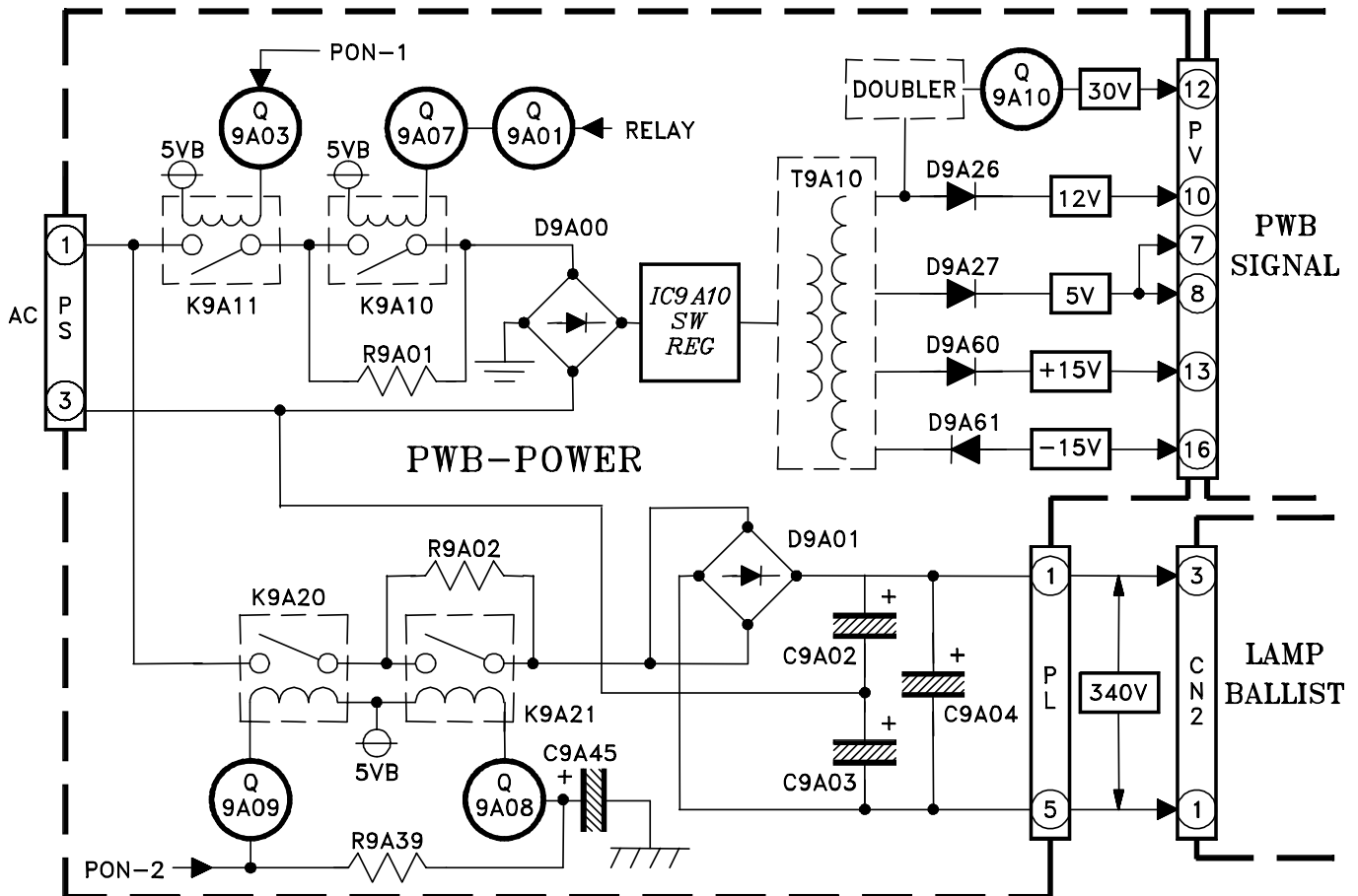

SWITCHED DC to DC SUPPLIES

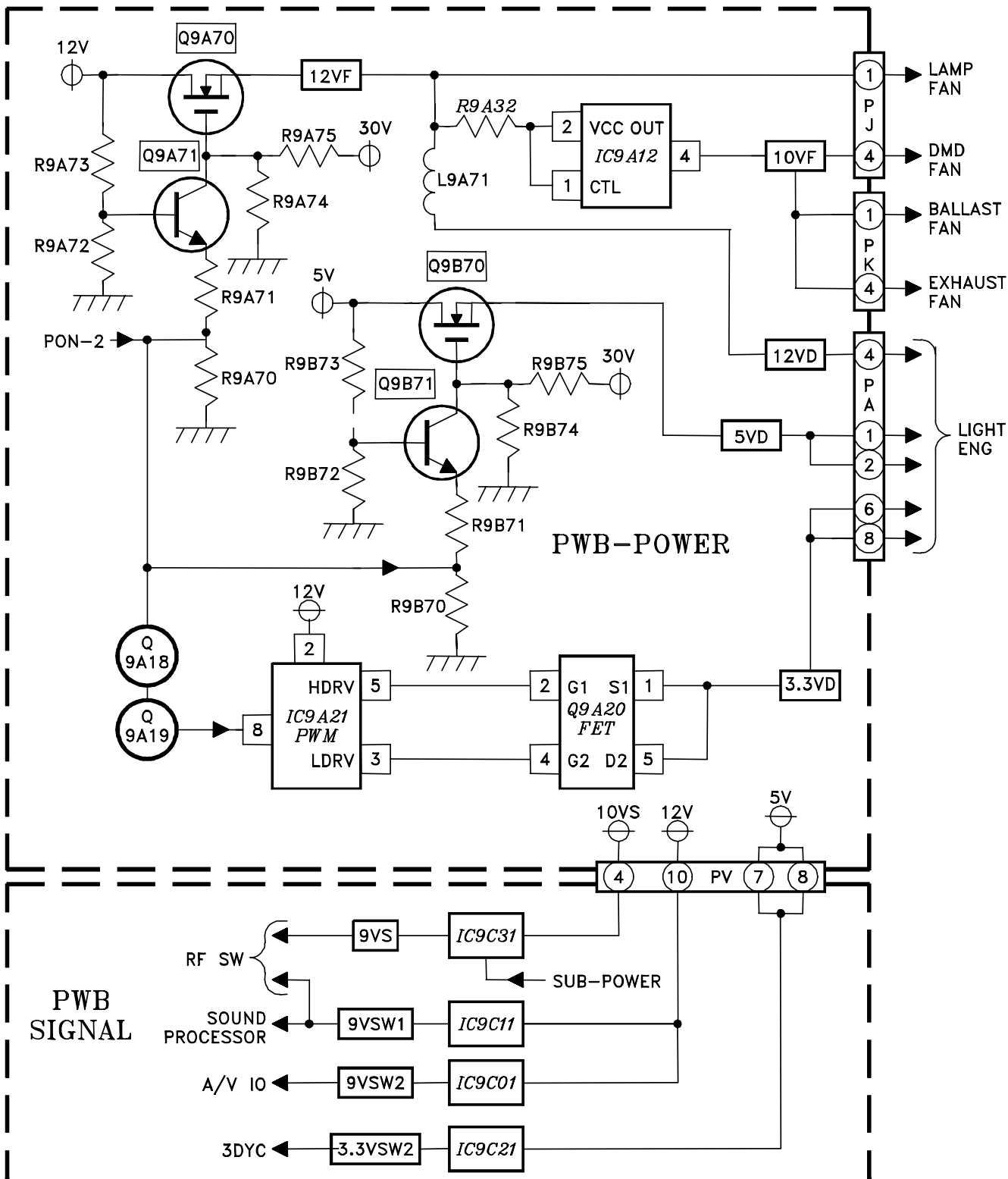

VIDEO/COLOR SIGNAL PATH

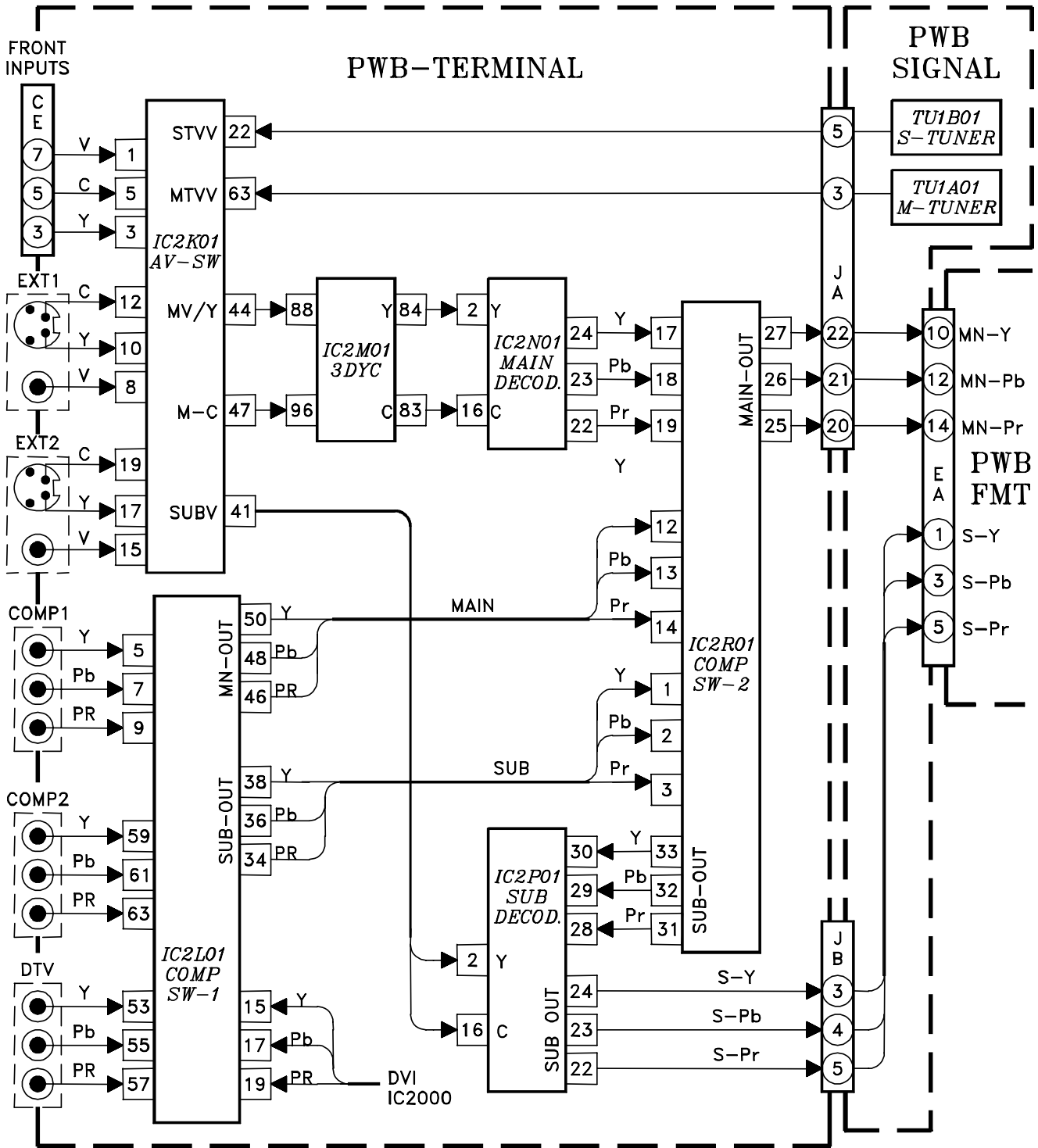

SOUND SIGNAL PATH

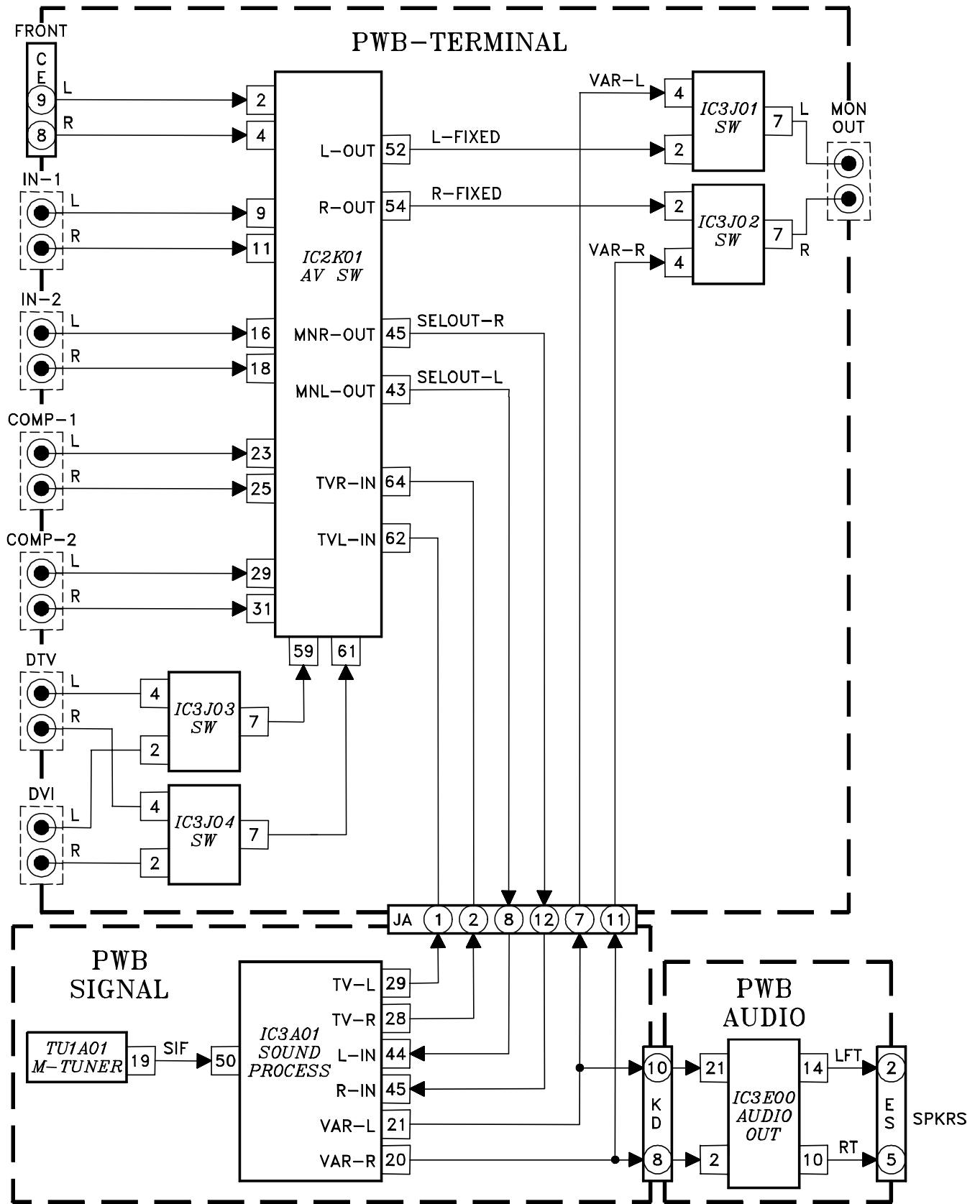

SYNC PATH

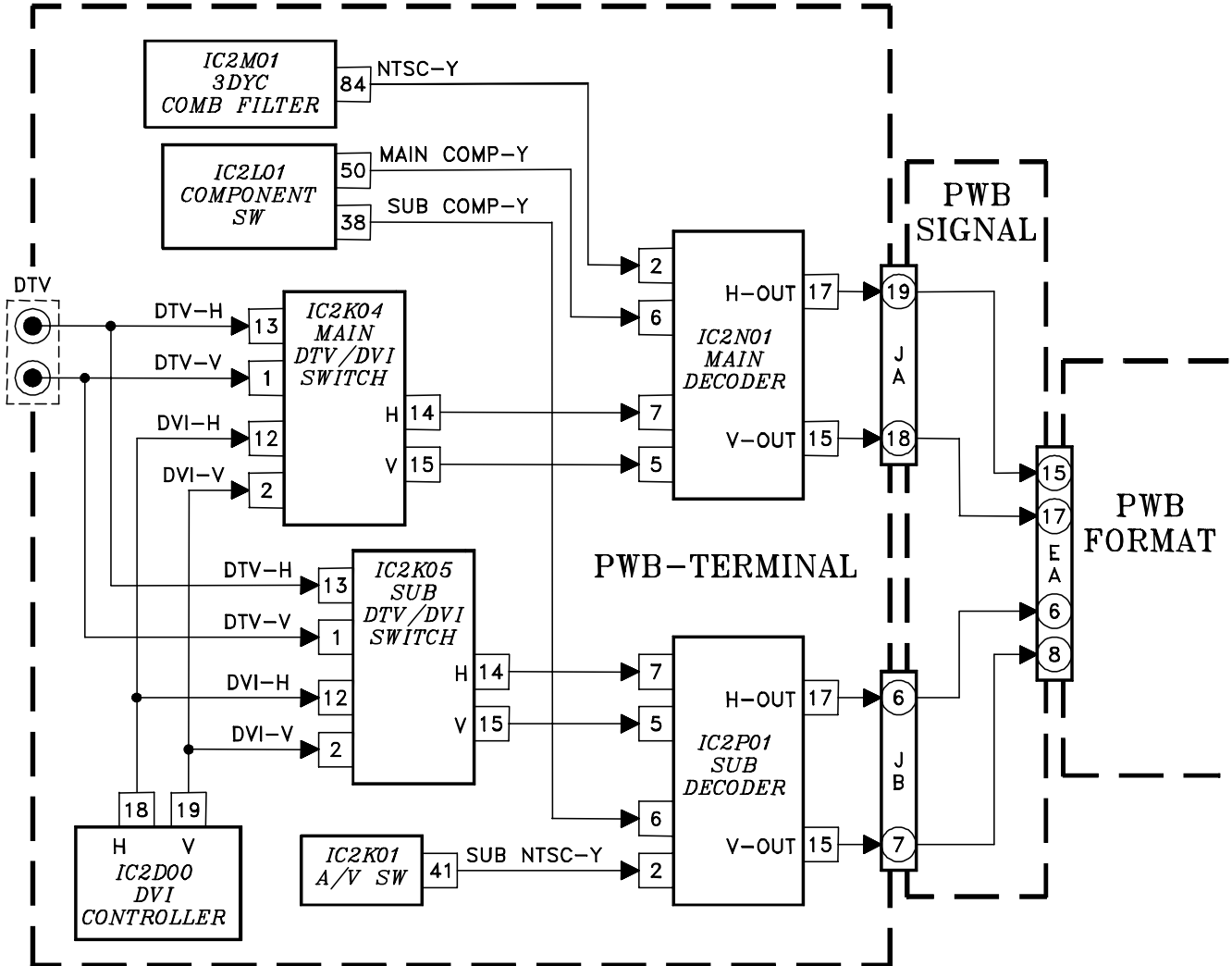

CONTROL CIRCUIT

- Input Commands
- Serial Data Lines
- Reset Circuit

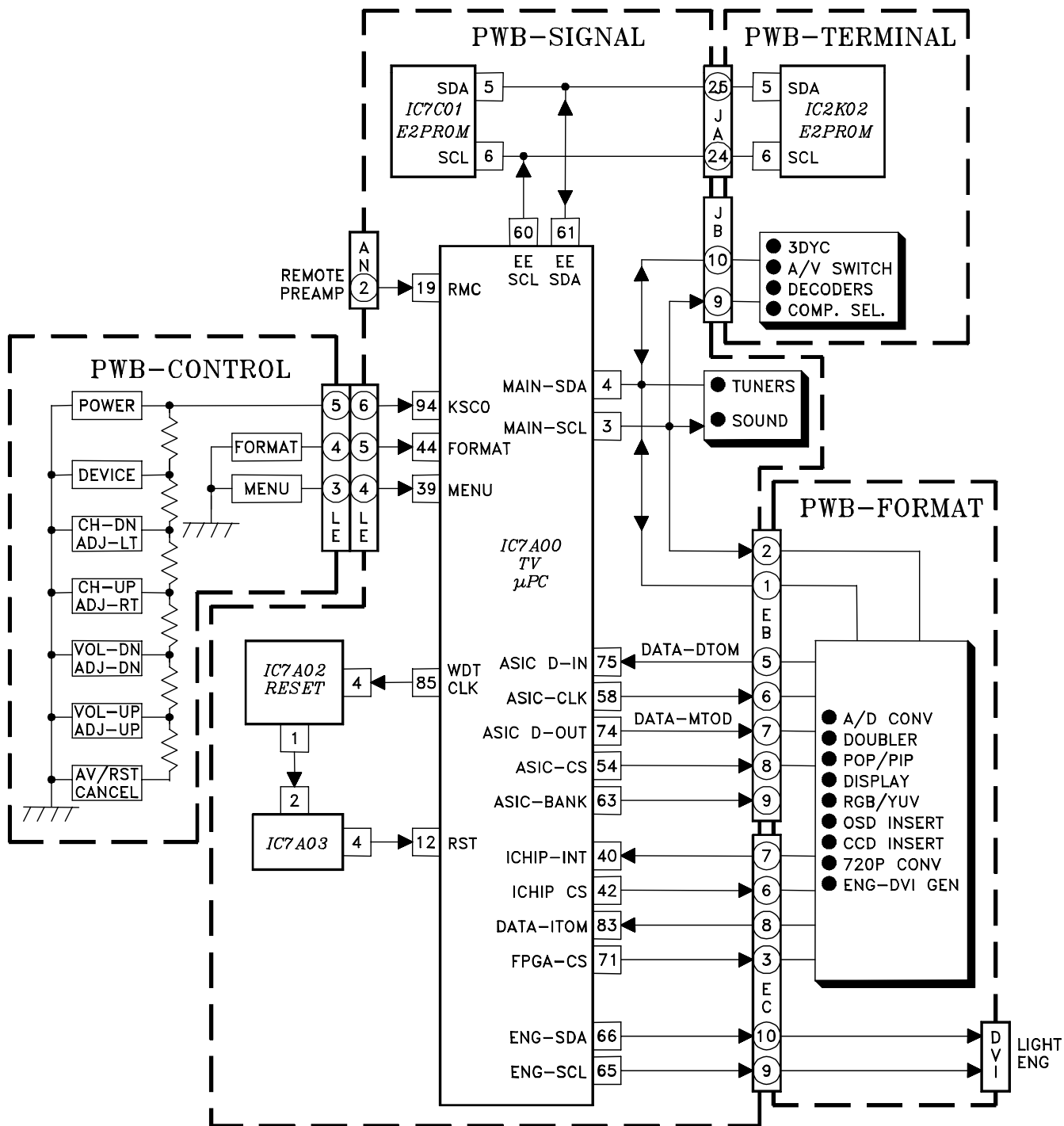

CONTROL CIRCUIT

- Status Input
- OSD Insert
- CCD Insert

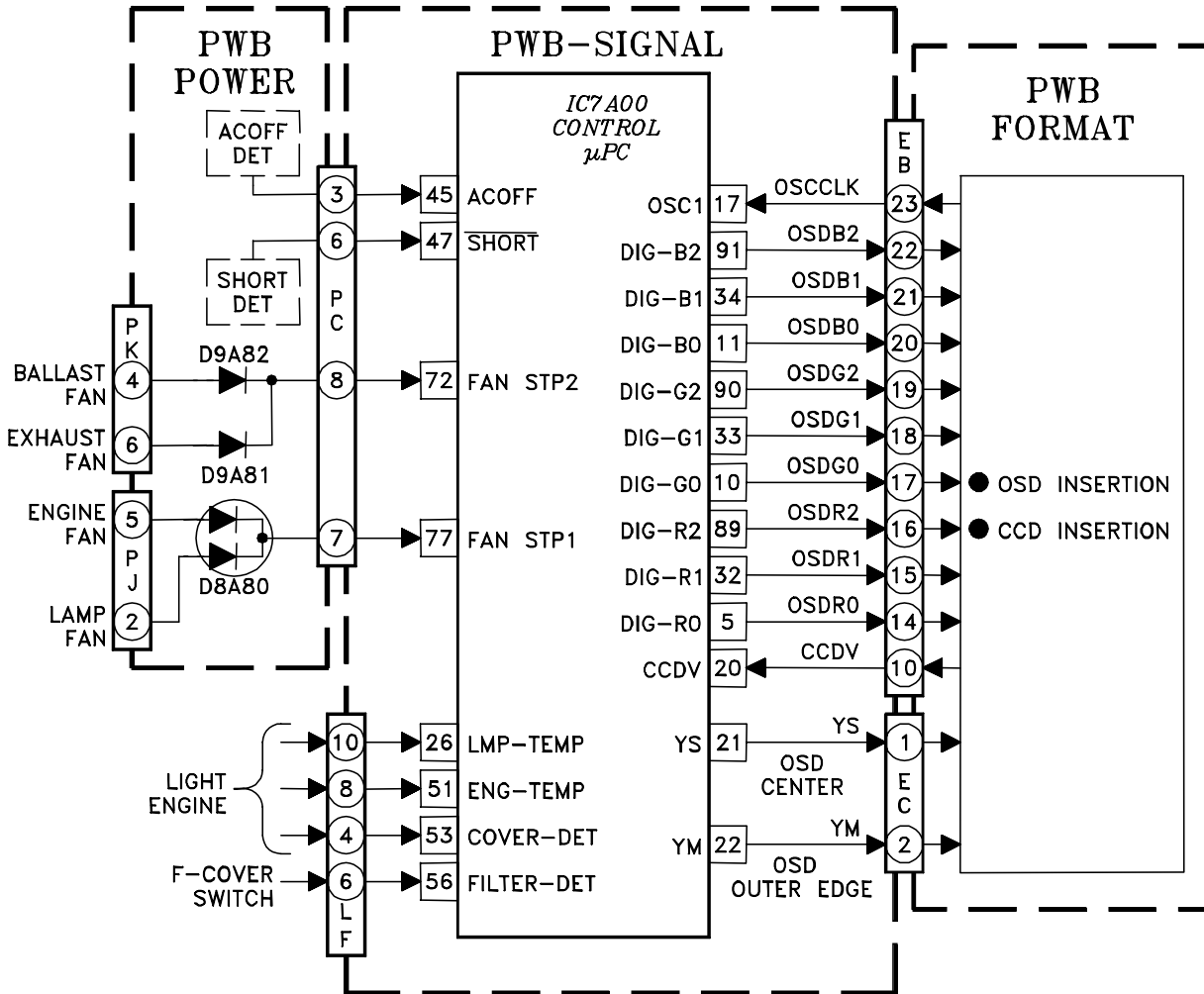

PWB-FORMAT BLOCK DIAGRAM

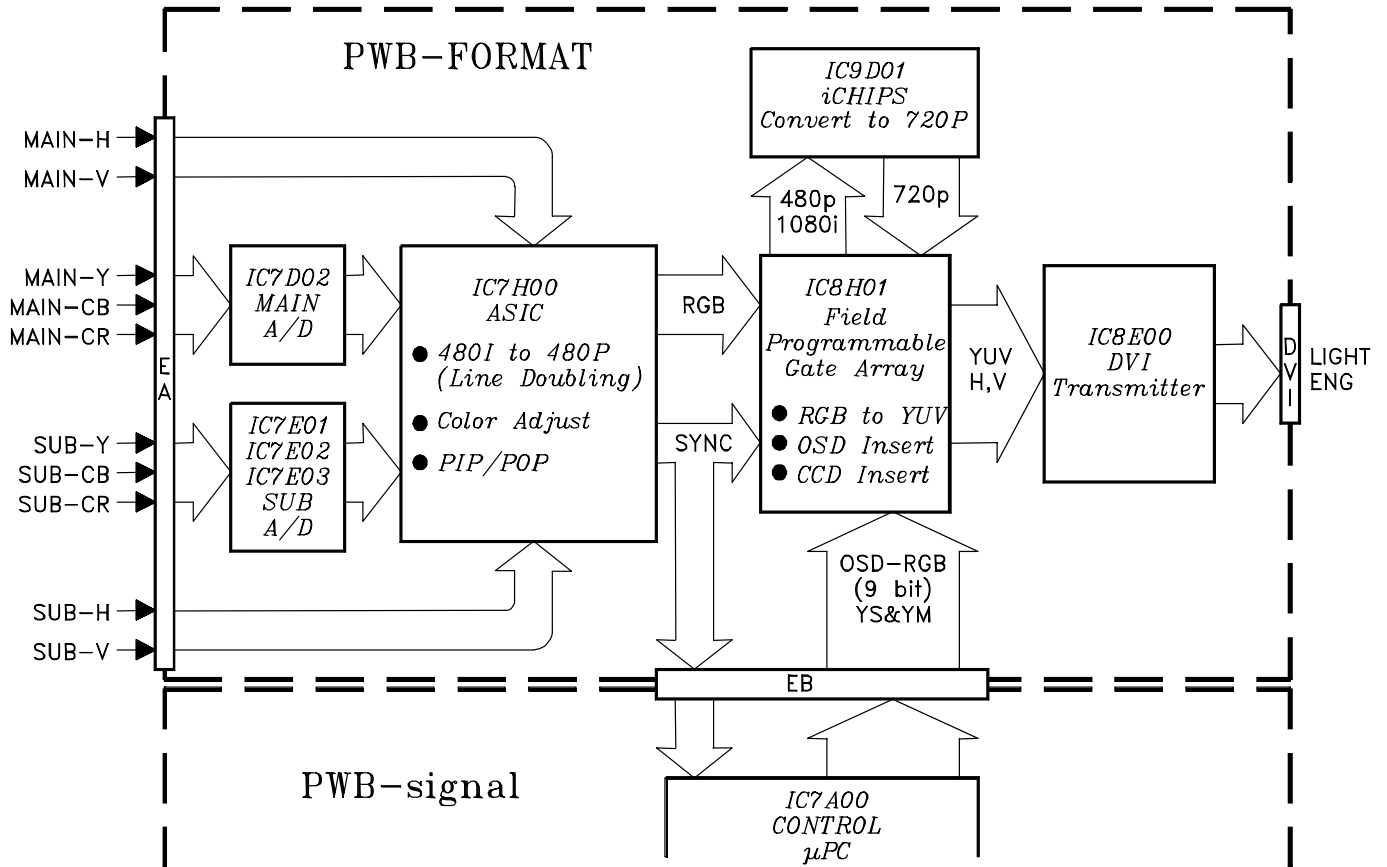

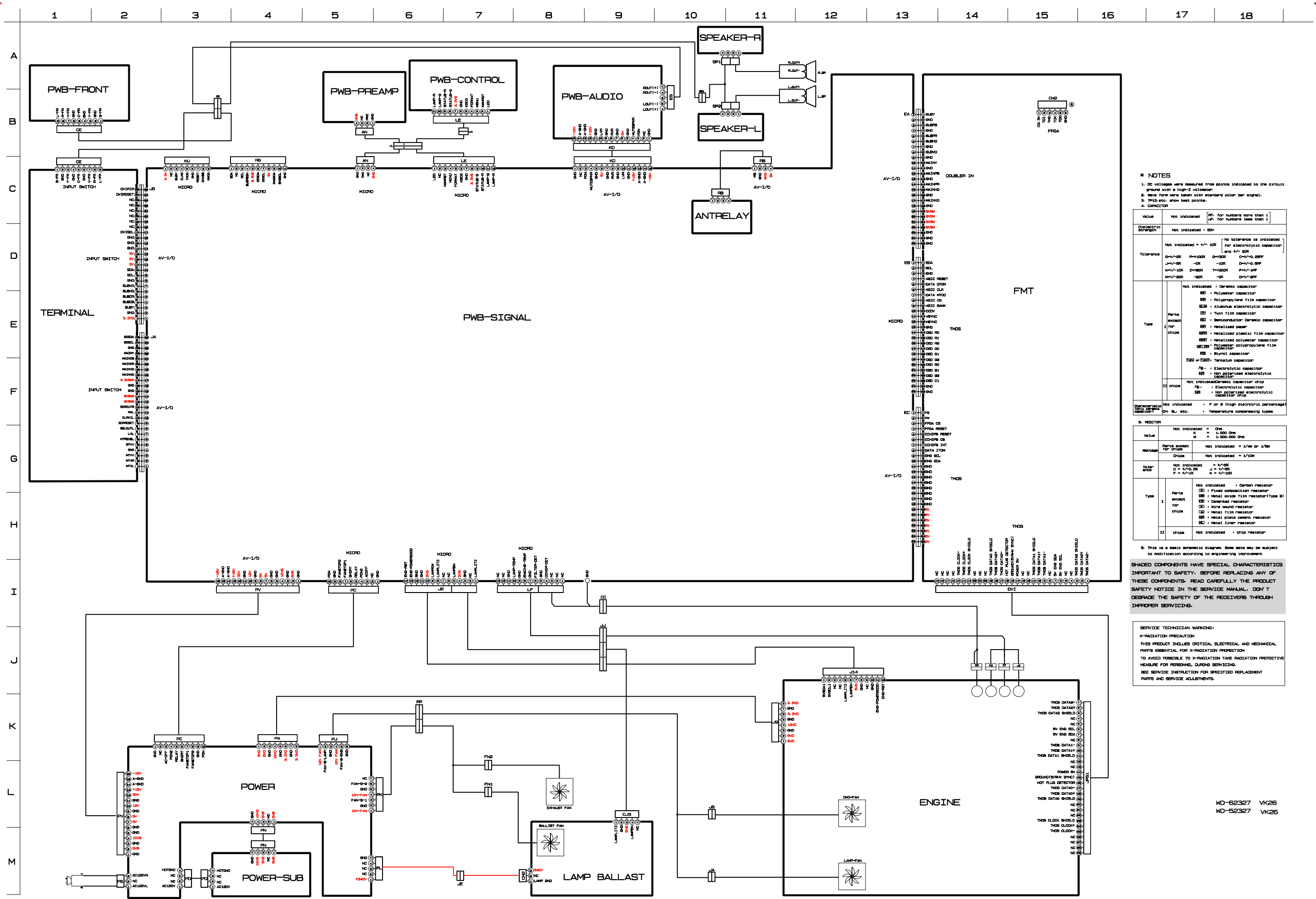

- * NOTES**
- DC voltages were measured from points indicated to the circuit ground with a high-Z voltmeter.
 - Wave forms were taken with standard color bar signal.
 - TP43 etc. show test points.
 - CAPACITOR

Value	Not indicated	[SP. for numbers more than 1] [LF. for numbers less than 1]
Dielectric strength	Not indicated	+50V
Tolerance	Not indicated	No tolerance is indicated for electrolytic capacitor and 4% 20K
Type	Parts except for chips	<ul style="list-style-type: none"> SEB: Polyester capacitor SEB: Polypropylene film capacitor SEB: Aluminum electrolytic capacitor SEB: Twin film capacitor SEB: Semiconductor ceramic capacitor SEB: Metallized ceramic capacitor SEB: Metallized polyester film capacitor SEB: Metallized polypropylene film capacitor SEB: Styrol capacitor SEB: Tantalum capacitor SEB: Electrolytic capacitor SEB: Non polarized electrolytic capacitor
	II chips	<ul style="list-style-type: none"> SEB: Not indicated ceramic capacitor chip SEB: Electrolytic capacitor SEB: Non polarized electrolytic capacitor chip

Value	Not indicated	One K = 1,000 Ohm M = 1,000,000 Ohm
Wattage	Parts except for chips	Not indicated = 1/4W or 1/8W
Type	Parts except for chips	<ul style="list-style-type: none"> SEB: Not indicated Carbon resistor SEB: Fixed composition resistor SEB: Metal oxide film resistor (Type B) SEB: Cemented resistor SEB: Wire wound resistor SEB: Metal film resistor SEB: Metal plate ceramic resistor SEB: Metal linear resistor
	II chips	Not indicated chip resistor

5. This is a basic schematic diagram. Some items may be subject to modification according to engineering improvement.

SHADED COMPONENTS HAVE SPECIAL CHARACTERISTICS IMPORTANT TO SAFETY. BEFORE REPLACING ANY OF THESE COMPONENTS, READ CAREFULLY THE PRODUCT SAFETY NOTICE IN THE SERVICE MANUAL. DON'T DEGRADE THE SAFETY OF THE RECEIVERS THROUGH IMPROPER SERVICING.

SERVICE TECHNICIAN WARNING:
X-RADIATION PRECAUTION
THIS PRODUCT INCLUDES CRITICAL ELECTRICAL AND MECHANICAL PARTS ESSENTIAL FOR X-RADIATION PROTECTION TO AVOID POSSIBLE TO X-RADIATION TAKE RADIATION PROTECTIVE MEASURE FOR PERSONNEL DURING SERVICING.
SEE SERVICE INSTRUCTION FOR SPECIFIED REPLACEMENT PARTS AND SERVICE ADJUSTMENTS.

WD-62327 VK26
WD-52327 VK26